

# **ISIMET – LSP Series Controller – Supplemental Wiring Instruction**

## **CONDUIT:**

ISIMET recommends that separate conduits be provided for each device that is controlled and integrated with each Controller. Do not incorporate wiring systems from a series of Controllers within a common conduit. Conduits for monitoring panels, arrays and panic assemblies should be separate from line voltage, control wiring and integrated system wiring. Where system components are mounted alongside the Controller within a common wall, install conduct for low voltage control wiring between the devices.

## **WIRING:**

### **Operating Power:**

Provide dedicated electrical service to the LSP Series Controller. Verify wiring requirements with Manufacturer's requirements. Minimum 15 amp circuit. A single circuit may provide service to multiply LA Controller provided that output load and operating limits do not exceed recommended limits for the unit.

### **Low Voltage Control Wiring:**

Provide 24 VAC control wiring from Controller to each controlled utility or device. Make connections at controlled device and terminate at output terminal on Controller's printed circuit. Minimum wiring, 18 AWG, plenum rated cable. Provide cable with required conductors plus two spares. Wiring should not be bundled or left in spools. Remove all excess wiring.

### **120-vac Output Wiring:**

120-vac line and neutral from individual LSP Units should be installed in independent conduit separate from wiring from other operating systems. Failure to follow this installation instruction may cause operating malfunctions.

### **Integrated Systems:**

Verify voltage and wire sizes to comply with requirements of each system.

### **System Monitoring Panels and Arrays:**

Provide 24 VAC control wiring from LSP Controller to each monitoring panel or array. Make connections at monitoring device and terminate at output terminal on Controller's pc board. Minimum wiring, 22 AWG, plenum rated cable. Provide cable with required conductors plus two spares.

### **Remote Panic Assembly:**

Provide 5 VDC control wiring from LSP Controller to each Remote Panic Assembly Panel within the classroom. Make connections at panel and terminate at Controller's pc board. Minimum wiring, 22 AWG, plenum rated cable. Provide cable with required conductors plus two spares. Where Drawings indicate two or more remote panels, connect each panel in parallel.

### **Control of Electrical Services:**

Where a multiple of circuits are to be operated by the Controller, then these circuits should be controlled by an E Series Companion Enclosure or other equivalent control device. The LSP Controller should be provided with a pc board configured to provide at least one 24-vac output in order to integrate with the interface relay on the E Series Enclosure. See "Recommended Wiring – Mechanically Held Contact" on reverse side.

## **Caution:**

Do not mount or locate any field provided electrical or mechanical devices within an ISIMET panel. Additionally, except for units operating power, unless clearly stated as acceptable on the enclosure wiring schematic, do not place any line voltage wiring inside an ISIMET control panel.



# Recommended Wiring – Mechanically Held Contact

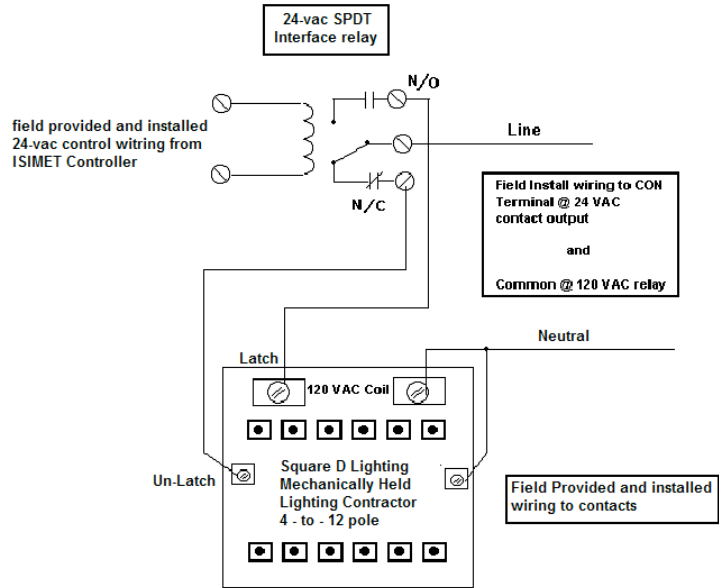

**All ISIMET Applications use either electrically held Square D - Master Control N/O Relays or Multipole Lighting Contactors to control the 120 VAC circuits to the convenience outlets.**

**Square D - Definite Purpose Contactors are used when a controlled device load demand exceeds normal operating amperes. All E-Series Companion Enclosures are equipped with an interface relay to enable the Utility Controller's output circuit to operate the contactors.**

**Contactor enclosure should be mounted in an accessible location.**

**If relays or contactors other than those provided by ISIMET are used in the application, ISIMET STRONGLY recommends that only this type of contactor be provided.**

**Additionally, an interface relay will need to be purchased from ISIMET to insure compliance with application installation requirements.**

**Caution !!!**

**Installations in non-compliance with these recommendations may cause the system to malfunction and may void the warranty of the Utility Controller.**

**Acknowledge Compliance Requirements:**

Contractor \_\_\_\_\_ Date \_\_\_\_\_