

## Servicing Procedures (Service should only be performed by a qualified service technician.)

Series 300 - fuel gas. Aluminum construction valves are standard for all *ISIMET* natural gas applications in sizes 1/2" – 3/4" – 1" – 1 1/4" - 1 1/2" – 2" valves.

Solenoids require periodic servicing to prevent failure of the valve. *ISIMET* recommends that the solenoids receive periodic, routine service. Debris that has lodged on the piston, in the solenoid valve orifice or diaphragm will prevent the proper operation of the valve. These valves are rated for low pressure systems and typically not intended to operate at pressures in excess of 5 oz.

If re-testing of the piping system is required per local jurisdiction, then care should be taken not to over-pressure the valve. Pressurizing the solenoid from upstream at pressures in excess of 15 psi will force the diaphragm to lodge inside the throat of the valve body. Refer to Figure below. The diaphragm will remain in this position even when the coil is energized. This will cause excessive stress on the coil and eventual failure. There is a risk that this coil failure will also cause other component failure including damage to the transformer or circuit board.

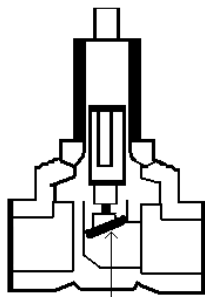

Diaphragm cocked in valve throat.

### Disassembling the solenoid valve for servicing. (typical)

**CAUTION!** Verify that power is turned OFF and service valve is closed prior to continuing.

3. Loosen and Remove the four (4) bolts that secure the valve bonnet on the valve body.

2. Remove coil body.

1. Loosen and remove threaded nut.



4. Remove the valve bonnet from the valve body.

Note: It is not necessary to remove the wiring connector from the coil.

### Typical image: 1/2" thru 1 1/4" valves have solid plunger, not diaphragm.

Separate the bonnet and piston springs (2).

(Springs may not be able to be removed from some pistons)

Keep the piston and diaphragm or plunger in tack.

Examine the internal core of the valve body, piston, diaphragm, or Plunger.

Remove any debris, metal shavings or oil. Thoroughly clean all parts.

Re-assemble the valve. Make sure piston, diaphragm, plunger and all springs are in place when re-assembling. Tighten all bonnet bolts.

Pressure test the reassembled solenoid.

Reassemble the coil, firmly tighten coil retaining hardware. Energize the coil to verify that the solenoid opens when energized and closes when de-energized.

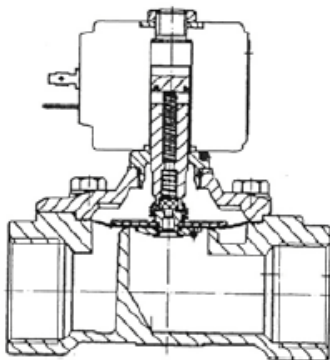

Typical Solenoid Valve Body Cross-Section.

*ISIMET* recommends that a maintenance log be maintained for each solenoid. And encourages that maintenance reports be faxed to *ISIMET* upon completion of periodic inspection / service.

# ISIMET Fuel Gas Solenoid Series 300 - Illustrated Parts List.

June, 2007



**Solenoid Coils:**

# SC-300 - 24vac # SC-301 - 120vac  
ExProof  
 # SC-307 - 24vac # SC-309 - 120vac

**Wiring Connectors:**

# SCC-300 - Conduit  
 # SCC-301 - Cable

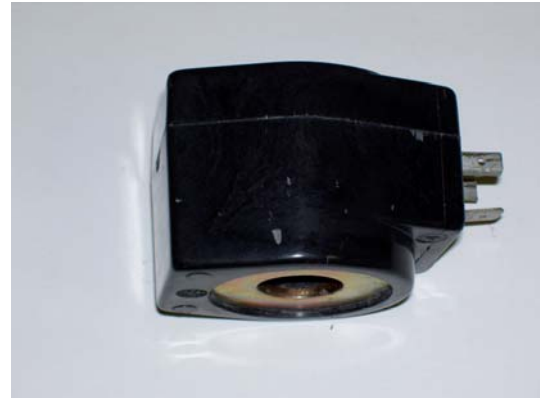

1 1/2" - 2" Solenoids

**Coil Retaining Hardware:**

# SP-330          Sizes 1/2" thru 2"  
 Includes nut & washer



1/2" - 3/4" - 1" Solenoids

**Solenoid Repair Kits:**

# SK-3 - 0 - X  
 Refer to chart below for X indicator  
 Kit includes Diaphragm or Plunger  
    Piston - O-Ring - Springs  
 Refer to chart below for X indicator

**Piston Upper Spring:**

# SP-310          Sizes 1/2" thru 2"  
 (Included in Repair Kit)



**Bolt-up Hardware:**

# SP-320          Sizes 1/2" thru 2"  
 Includes 4 each bolts / washers



**Solenoid Bonnets: # SB-3 - 0 - X**

**Solenoid O-Ring: # SP-3 - 0 - X**

Refer to chart below for X indicator

**Solenoid Valve Body:**

Not Sold separately.

"X" Indicator Chart:    1 - 1/2"    2 - 3/4"    3 - 1"    4 - 1 1/4"    5 - 1 1/2"    6 - 2"