

# ***ISIMET* Laboratory Service Panel Solenoid Enclosure**

## **Installation, Maintenance, and Operation Instructions**



The *ISIMET* Laboratory Service Panel operates as a single output controller incorporating either a solenoid valve assembly or electrical contacts along with the digital switching mechanism within a single enclosure. An internal junction box houses the 120-vac line voltage along with transformer and circuit board.

<b>Table of Contents:</b>	
	<u>Page</u>
Warranty .....	2
Model Numbers .....	3
Enclosure Specifications & Dimensions .....	3
Installing the Enclosure - Figures 1 & 2 .....	4
Parts List - Figure 3 .....	5
Ball & Solenoid Valve Specifications .....	5
Inlet and Outlet Fitting Options – Figure 4 .....	6
Enclosure Piping Connections – Figure 5 .....	7
Wiring Information .....	7
Internal Junction Box – Figure 6 .....	8
Wiring Schematic – Single or Dual Output – Figure 7 .....	8
Circuit Boards Input/Output Configurations – Figure 8 .....	9
Jumper Configurations Figure 8-a .....	9
Removing and Re-installing Door Panel .....	10
Operation of the Service Panel .....	11
Routine Maintenance.....	11

## ***ISIMET***

Laboratory Service Panel  
Installation, Maintenance, and Operations Instructions

Copyright © 2009 ***ISIMET***, LLC.  
All rights reserved.  
Patent 6,757,589 B1  
Other Patents Pending

This document is copyrighted. This document may not, in whole or part, be copied, duplicated, reproduced, translated, electronically stored, or reduced to machine readable form without prior written consent from ***ISIMET***, LLC.

Although the material contained herein has been carefully reviewed, ***ISIMET***, LLC does not warrant it to be free of errors or omissions. ***ISIMET*** reserves the right to make corrections, updates, revisions, or changes to the information contained herein.

***ISIMET*** is a trademark of ***ISIMET***, LLC.

### **Warranty:**

***ISIMET*** will repair or replace any defective parts or workmanship of this product for a period of one year from date of installation. The P.C. Board has a two year limited warranty. Damage caused by incorrect installation or improper usage is not warranted. Failure to follow recommended installation, operation, and/or maintenance procedures listed in this manual may void product warranty. Recovery rights shall be limited to the total sum of the amounts paid for the product by the purchaser.

***ISIMET*** warrants the solenoid to be free from defects in materials or workmanship when incorporated into an ***ISIMET*** Control System for a period of one hundred and eighty (180) days from the date of installation by buyer. Otherwise, for a period of ninety (90) days. If the equipment or any part thereof becomes defective within the warranty period, the defective equipment will be replaced or credit allowed therefore at the sole option of ***ISIMET***, but without credit or payment for any labor.

Damage caused by incorrect installation or improper usage is not warranted. Failure to follow recommended installation, operation, and/or maintenance procedures listed herein may void product warranty. Recovery rights shall be limited to the total sum of the amounts paid for the product by the purchaser.

**General Service Solenoids:** ***ISIMET*** cannot warrant against the effects of hard water, corrosive agents, contaminants, or debris present in the piping system or against effects of exotic or harsh substances.

### **EXTENDED WARRANTY:**

***ISIMET*** will extend the warranty of this product to a period of two years from date of installation (solenoids for one year) when installation complies with all start up and routine maintenance procedures. Refer to Extended Warranty Policy.

### **Limits of Liability:**

***ISIMET***'s liability shall be limited to costs of repair or replacement parts. The Laboratory Service Panel and Utility Controller are not intended for usage other than those expressly described in this manual. ***ISIMET*** shall not be liable for damage or injury caused by the improper use of the product.

***ISIMET*** does not warrant against or assume liability for failure of operation or lack of notification to secondary integrated monitoring systems. The system should be thoroughly tested and adjustments made at time of initial operation. Periodic testing should be conducted by the user to assure that all components function and operate according to specifications.

Care should be taken in the installation of this product. ***ISIMET*** shall not be liable for damage or injury caused from the improper installation of the product.

Warranty is Subject to Compliance with Specific Installation Requirements.

### **DISCLAIMER OF IMPLIED WARRANTY:**

**THERE ARE NO WARRANTIES THAT EXTEND BEYOND THE DESCRIPTION HEREIN. SELLER DISCLAIMS ANY IMPLIED WARRANTY OF MERCHANTABILITY OF THE GOODS OR OF THE FITNESS OF THE GOODS FOR ANY PURPOSE, AND BUYER AGREES THAT THE GOODS ARE SOLD "AS IS."**

Printed in the United States of America.

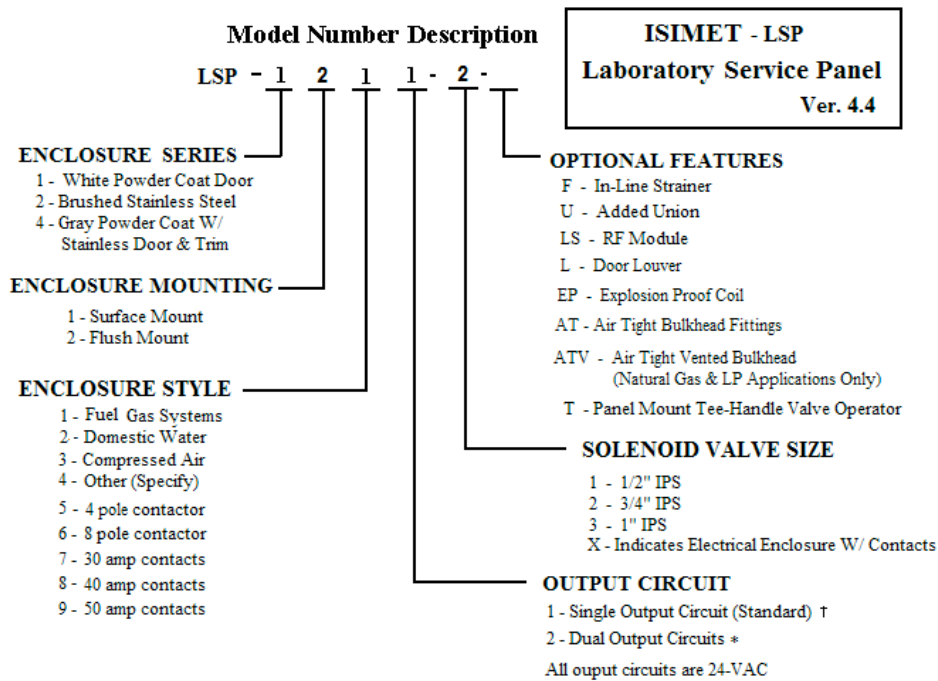

† Field Configurable Notification Output Circuit is Standard on all Systems

\* Second Output Circuit is intended for operation of a remotely located 24-VAC device.

**UL:** Product is in compliance with the Industrial Control Panels, UL 508A Standard. Not available for all units where specific application does not conform to UL-508A criteria.

### Enclosure Specifications and Dimensions:

The NEMA 1 enclosure may be either surface or flush mounted. Flush Mount with Trim Kit is Standard. Door is provided standard with a Key Lock. These units are not suitable for direct exposure to wet conditions. The Two Styles of the Enclosure are:

**Solenoid** - The unit is equipped for either natural gas or fluid system applications (domestic water). This unit features a manual shut-off valve with a 24-vac N/C solenoid with fittings. The solenoid is pre-wired to the output circuit at the printed circuit board. Refer to ISIMET Solenoid Specifications for valve specifics. Sizes range from 1/2" – 1" IPS. All units are provided with rubber grommets – Standard. Optional Air Tight and Vented Enclosures are provided with liquid tight bulkhead fittings or threaded lock-nuts for the piping connections at the top and base of the Enclosure. All solenoids are provided with reset switches.

**Electrical** - A three (3) pole definite purpose contactor from 30 – 50 amp, a four (4) pole, or an eight (8) pole mechanically held lighting contactor is provided within the enclosure.

**This manual addresses the Solenoid Style only.**

The valve assembly is arranged within the enclosure to insure ease in making field piping connections. Wiring leads for solenoids are terminated at the printed circuit board (PCB) within the junction box.

Enclosure dimensions are 16X14X6 – 18X18X6

Available in 24X24X8-Custom assembly for multi valve assemblies and larger sized piping. (also permits horizontal configuration of valve assembly,)

The enclosure is available in White Powder Coat Door, Gray Powder Coat with Brushed Stainless Steel Door, And Brushed Stainless Steel.

# Installing the Enclosure

There are two options for mounting the Laboratory Service Panel: Flush Mounted and Surface Mounted.

## Flush Mounted

Prior to installation:

- The Enclosure mounts between two standard spaced wall studs within a minimum 6" wall cavity. (See enclosure dimension – page 3)
- If stud spacing is greater than that required for the mounting of the controller, add studs to insure a secured mounting.
- The studs should be facing to facilitate securing the Enclosure.
- Predetermine wall finish so that the face lip of the enclosure aligns flush with the finished wall surface.

To install:

1. Using the self-starting screws (13), mount the flanges at each side and at the top and bottom of the enclosure.
2. Attach the enclosure to the wall studs with field-provided sheet metal screws per the drawing.
3. Level the enclosure.

### Notes:

- When the Door Panel is mounted onto the Enclosure, it should protrude beyond the wall surface about 1/4". Care should be taken at installation time to ensure that this occurs.
- A Flush Mounting Trim Flange is provided with each flush mounted unit. Separate installation instructions and hardware are included with this flange.
- Semi and Flush Trim add 3.5 inches to both Height and Width wall surface dimensions.

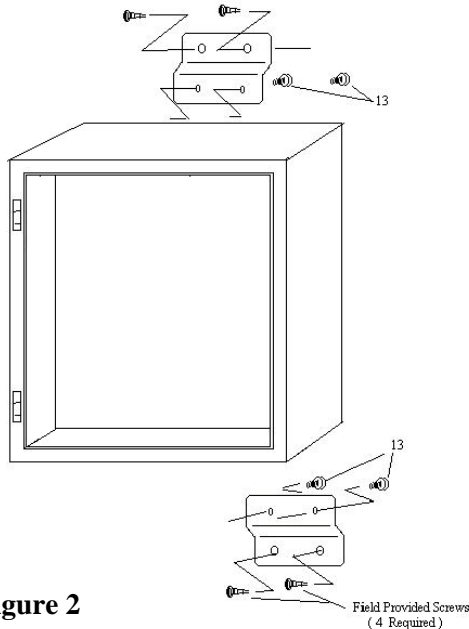

**Figure 2**

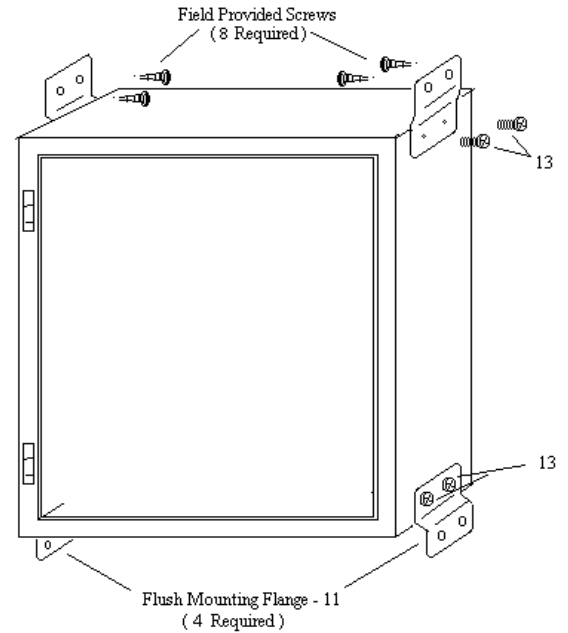

**Figure 1**

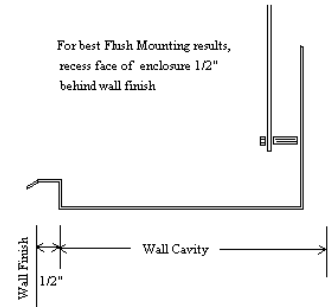

**Clearance around Enclosure:**

Care should be taken to allow 1/2" clearance from wall framing and sheet-rock or other wall surface material around the outer surface of the unit to permit the trim to be properly installed.

## Surface Mounted

Prior to installation:

- Wall finishes should be complete.
- The wall cavity must have sufficient backing or support to ensure a firm mounting of the enclosure to the wall surface.

To install:

1. Secure the surface mount flanges to the back of the enclosure with the self-starting screws (13).
2. Use the field-provided screws to attach the enclosure by the flanges to the wall surface.
3. Level the enclosure.

**Parts List:**

1. IPS Service Cut-off Ball Valve
2. Solenoid Valve
3. Union
4. Pipe Nipple
5. Pipe Clamp
6. Aluminum Strut Support
7. Electrical Junction-Box
8. Enclosure
9. Inlet / Outlet Holes
10. Door Panel (Not Shown)

**Figure 3**

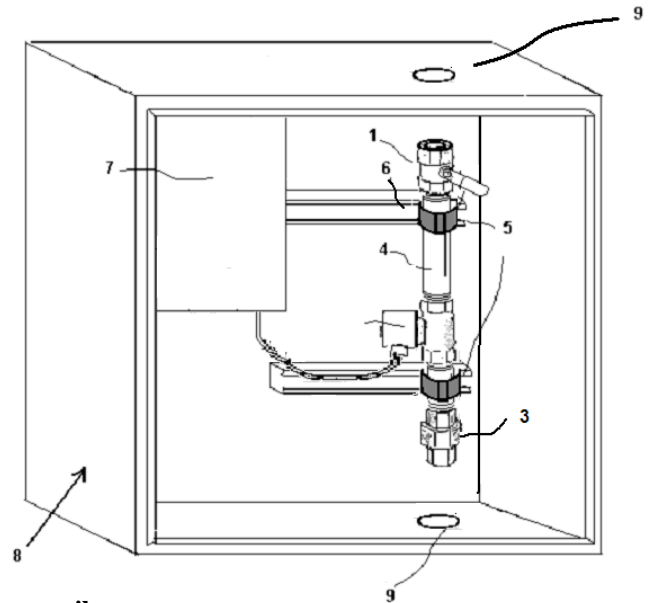

**Solenoid Valve Specifications: All solenoids are provided with 24-vac coils.**

The General Service Solenoid Valves are UL Listed NPT from 1/2” thru 1” in size and are of brass construction unless stated otherwise. Operating Mode: (Standard) Normally Closed – Closed when de-energized.

Maximum operating temperature for the solenoid is 180° F / 82.2° C

Coil Rating: Continuous duty totally encapsulated

Voltage Tolerances: +10%, - 10% of applicable voltage

All Solenoid Coils have a NEMA 1 Rating

**Series 300 - fuel gas. Aluminum construction UL Listed valves are standard for all ISIMET natural gas applications in sizes 1/2” – 3/4” – 1” .**

**Solenoid Valve Model Numbers:**

ISIMET Model	Port Size (in)	Orifice Size (in)	Min. Pressure Diff.	Flow Factor Cv	Operation Pressure		Coil (watt)	24/60 VAC		120/60 VAC	
					Air/Gas psi (MAX.)	Water psi		VA	VA	VA	VA
								Inrush Holding		Inrush Holding	
S-101	1/2	5/8	0	2.8	200	200	8	25	14.5	25	14.5
S-102	3/4	5/8	0	2.8	200	200	8	25	14.5	25	14.5
S-103	1	1	0	8.3	116	116	8	25	14.5	25	14.5
S-201	1/2	5/8	3	4.2	225	225	6	25	14.5	25	14.5
S-202	3/4	5/8	3	6.4	225	225	6	25	14.5	25	14.5
S-203	1	1	4.5	10.5	225	225	6	25	14.5	25	14.5
S-301	1/2	.75	0	4.095	2.9	171,600 *	13	45	27	45	27
S-302	3/4	.75	0	5.265	1.45	241,500 *	13	45	27	45	27
S-303	1	1.0	0	11.7	0.725	635,500 *	13	45	27	45	27

\* BTU at 0.60 Specific Gravity with pressure drop of 0.5 inch water column.

**Ball Valve Specifications:**

**Ball Valve: Nibco or Apollo** Bronze 2-Piece Ball Valve (or equivalent)

For use with domestic water, natural gas, compressed air systems

Valve Station Suffix “TUT” – Double Threaded Union & “SUT” – Solder X Threaded Union (Through 1”)

“XU” non-union “TU” – Threaded Union “SU” – Solder Union.(1 ¼”, 1 ½”,2”).

Full Port – IPS ¼ turn vinyl insulated handle 600 psi WOG non-shock.

Valves for fuel gas systems are UL Listed but are not available with the integral input union. (XU)

**Notice:**

**Piping system should be thoroughly flushed and cleaned prior to operation. If systems are operated without proper flushing, the solenoid diaphragm may become fouled and may not close properly when solenoid coil is disengaged. Fluid delivery systems should be provided with shock arrestors and in-line strainers. Enclosures are not provided with an integral in-line strainers, but one should be field provided directly up-stream from the solenoid assembly. The piping joints within the enclosure should be tested to assure tight connections.**

**Parts List:** (Optional bulkhead components)

- “AT” Suffix - Air Tight Bulkhead Fitting  
- two (2) per assembly
- “ATV” Air Tight with Vent - IPS Lock nut  
- four (4) per assembly

All Natural Gas & LP assemblies are provided with Black Pipe Fittings and Style 300 Solenoids

All other assemblies use brass fittings.

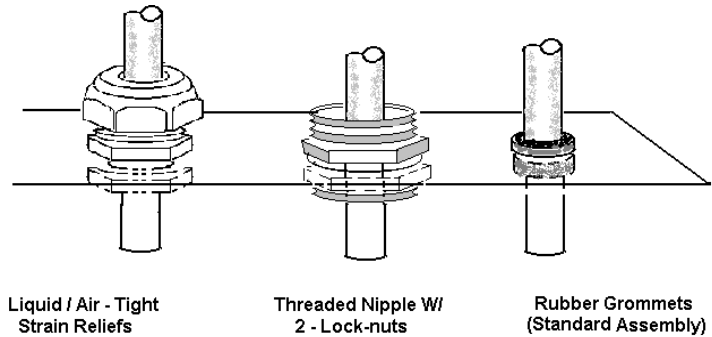

Inlet and Outlet Fittings for Enclosure  
Inlet view shown - Outlet similar

**Figure 4**

**Inlet and Outlet Fittings Options:** Inlet view shown – outlet similar

Inlet – Outlet Fittings: Two (2) sets of shown fittings for the station is provided with the enclosure dependent upon the style of enclosure specified.

Sealant/Adhesive should be applied around the attachment threads before insertion into the enclosure holes for all Air Tight and Air Tight with Vent Enclosures.

Connections to secondary containment piping should be connected to outlet end of vent fittings with interior ends left open.

**Routine Maintenance: (Solenoids & Piping Systems)**

Periodic examination and testing of the piping system should be performed to assure that the solenoids are functioning properly and that no foreign debris has lodged in the solenoid valve orifice, preventing the proper operation of the valve.

**Caution:**

Pressure testing for fuel gas system solenoids should not exceed 15 psi at the body of this valve due to potential damage caused by excessive pressure applied to the diaphragm.

Coils should not be energized unless secured to the valve core. Coils will heat during operation. A temperature of  $\pm 150^\circ$  is not uncommon.

## Enclosure Piping Connections:

When making service piping connections, provide back-up restraint at the assembly so as to prevent the turning of the valve assemblies. Disrupting the factory piping connections may cause leakage.

Care should be taken for all Air Tight and Air Tight with Vent enclosures to assure that sealant/adhesive is applied at all penetrations and that connecting fittings are made air tight.

## Testing & Cleaning the Piping System:

The piping system should be thoroughly tested and cleaned of all foreign matter and debris prior to placing the enclosure into service.

The piping joints within the enclosure should be tested to assure tight connections. Do not exceed 15 psi test on any fuel gas system solenoid from upstream. Damage to the coil may result when first energized.

## Installing the Electrical Conduit

Knockout holes for connecting the electrical conduits are located at the top left and side of the Enclosure.

- Connect rigid conduit for the required 120-vac electrical service to the top inlet.
- Connect conduit for second remotely located output devices at the side of the enclosure. (Dual Circuits only.)
- Connect conduit for integration input & output signal cables at the upper left side knock-out.

## Electrical Specifications:

Style	# Output Circuits	Output Rating	Transformer	Relay Rating
LSP	1	1.5 amp @ 24 vac	2 amp @ 25VCT *	1 @ 1.5 amp @ 24 vac
LSP	2	1.5 amp @ 24 vac	3 amp @ 25VCT *	1 @ 1.5 amp @ 24 vac
LSP	Custom	1.5 amp @ 24 vac	3 or 4 amp @ 25VCT	1.5 amp MAX.

**Caution:** All local codes and regulations should be followed when installing the enclosure and making the piping and conduit connections.

## Wiring the Unit:

**Important! Verify that the electrical supply is disconnected prior to connecting wiring to the Service Panel.**

To wire the Service Panel:

1. Remove the junction box cover.
2. A secondary Switch Box with fuse holder and cover is located at the top of this box. Remove this cover.
3. Make final connections to the 120-vac electrical service to wiring within the junction box (Figure 6). Verify that line wiring (Black), neutral (White), and ground wire (Green) are correctly connected. Minimum recommended wire size is 14 AWG.
4. Replace this cover before activating or testing the unit.
5. The solenoid coil is pre-wired to output terminal "CON 3", posts 1 & 3 on the PC Board. Verify that wiring has not become disconnected during installation.
6. If the unit is equipped for Dual Output Circuits, also see Figure 7 and additional instructions on page 8.

## Input & Monitoring Circuits and Configuration pins: Figures 8 & 8-a, page 9.

**DO NOT route wiring to or from Input or Monitoring Circuits within conduit containing either 120-vac line or 24-vac control wiring operating a controlled inductive load. Failure to comply with these wiring specifics may create transient voltage at the pc board and cause system malfunction and/or failure.**

Figure 5

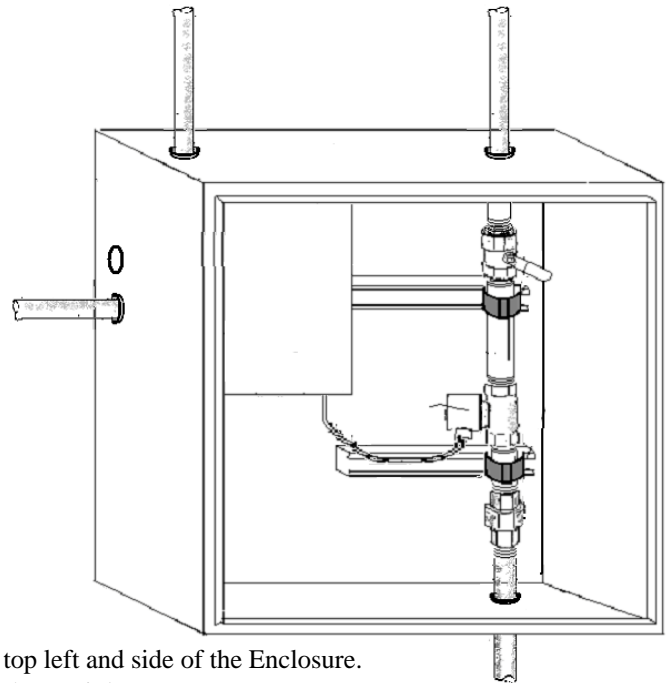

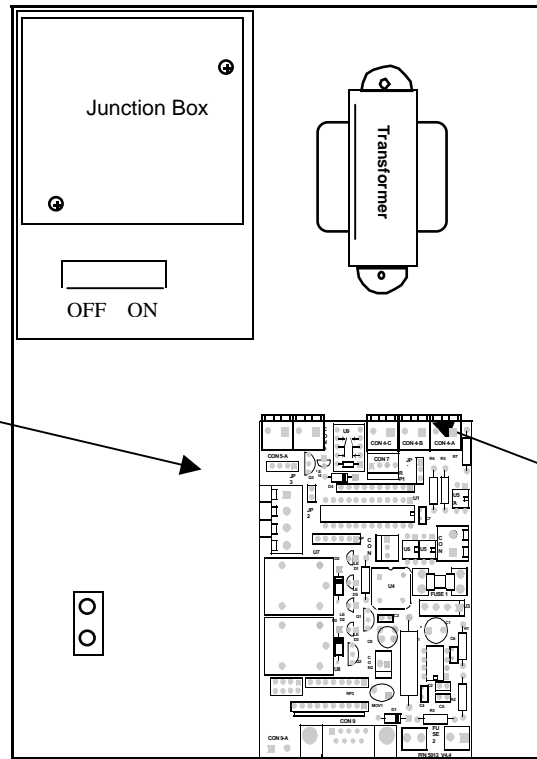

**Figure 6**

Connection of Solenoid  
24-vac @  
posts 2 & 3 for  
single outputs

OR

Dual outputs  
posts 1 & 3  
Remote Output  
posts 2 & 3

Connector 4 Alarm  
Input Remote Panic  
Input "ems" Input

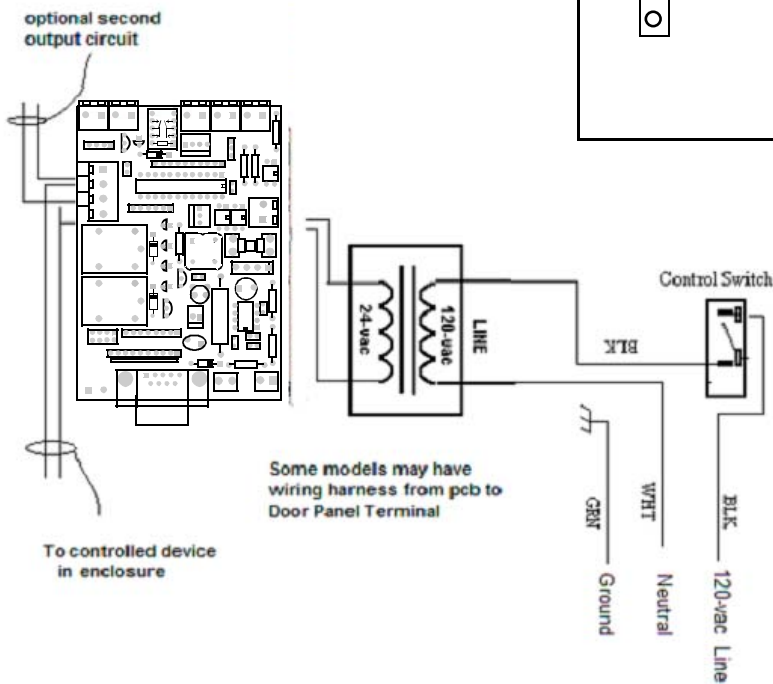

Door Panel Plug  
Receptacle

**Figure 7-a**

Standard pcb jumper wiring configuration. Unit can be factory configured @ 10 pin terminal to accept a dual control RF module.

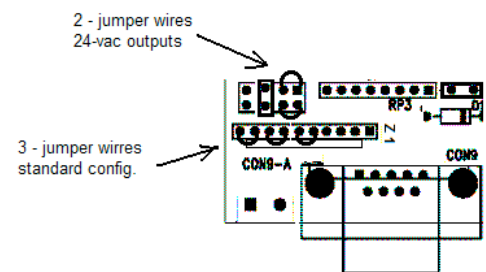

**Figure 7**  
**Wiring Schematic – Single or Dual Output Circuits**

**Dual Output Circuits where second output is to a remotely located device.**

**Note: Maximum output load for second circuit is limited to 1 Amp.**

Make field wiring connections as shown in Figure 7 for a remotely located device to be controlled by the Service Panel. Panels may be custom assembled in enlarged enclosures to permit second output device to be located within Service Panel.

**Figure 8**  
Printed Circuit Board Output –  
Jumper Configurations

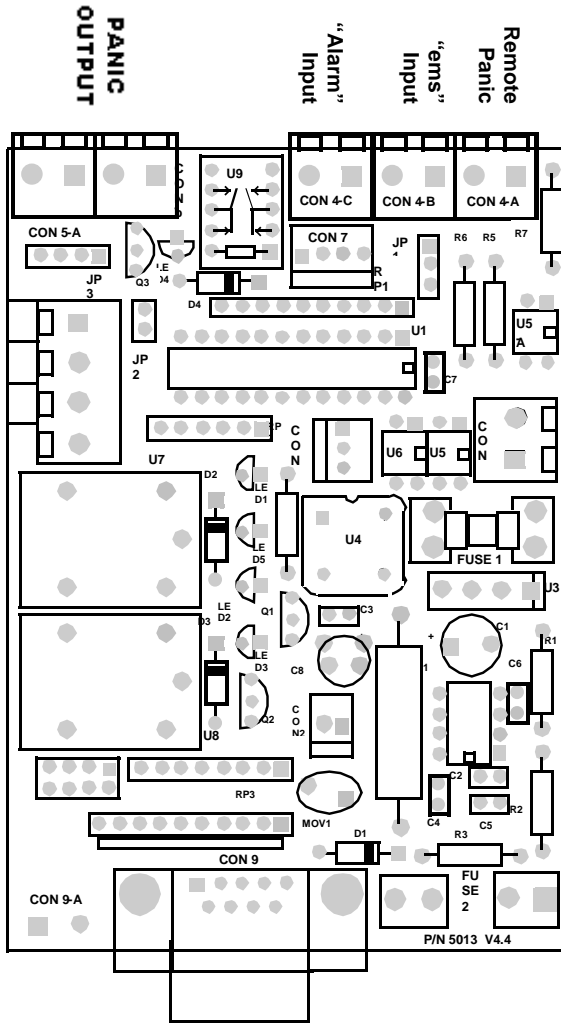

**Figure 8-a**

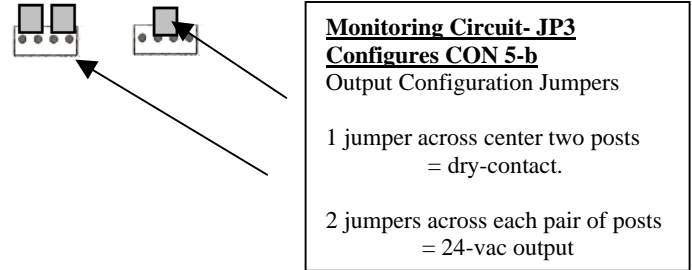

**Connecting the Monitoring Outputs:**

The “pcb” is equipped with two output monitoring ports. The configurable “Panic Output” CON 5-b can be configured at JP 3 to provide either 24-vac output or dry-contact. Refer to Figure 8-a.

CON 5-b provides a dry-contact output upon *Panic*. Con 5-a is fixed dry-contact output.

**Connecting Input Integration Signals: Figure 8**

Remote Panic: Connect an ISIMET Remote Panic Assembly @ CON 4-A.

“ems” Input: 24-vdc/vac active HI will disable the operation of the unit.

Alarm Input: 24-vac/vdc active HI. Refer to jumper configuration chart above.

## Removing and Re-installing the Door Panel

**CAUTION:** Before removing the door panel, unplug the door panel from the receptacle at the base of the junction box.

To install the Door Panel on the Enclosure:

1. Position the door at 90° – 100° of enclosure.
2. Slide top hinge pin onto fixed hinge post at top of door.
3. Slide lower hinge pin toward lower spring hinge mechanism with hinge pin lever in retract position.
4. With lower hinge pin in position, turn hinge pin lever outward and down, then turn inward to the extended lock position.
5. When re-installing the door, make sure that the door panel plug is securely inserted into the plug receptacle located at the base of the internal junction box.

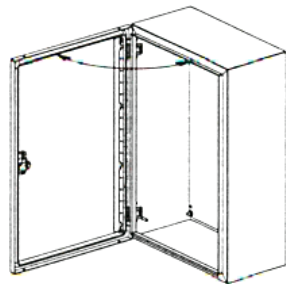

STEP 1

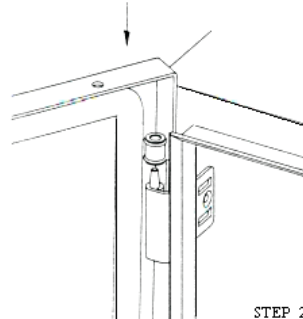

STEP 2

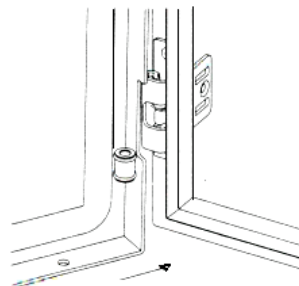

STEP 3

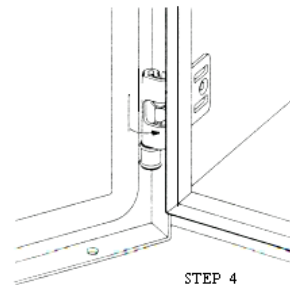

STEP 4

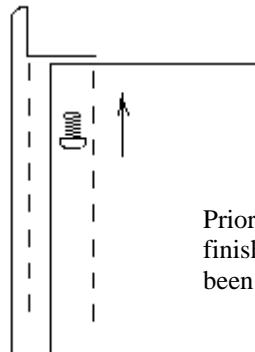
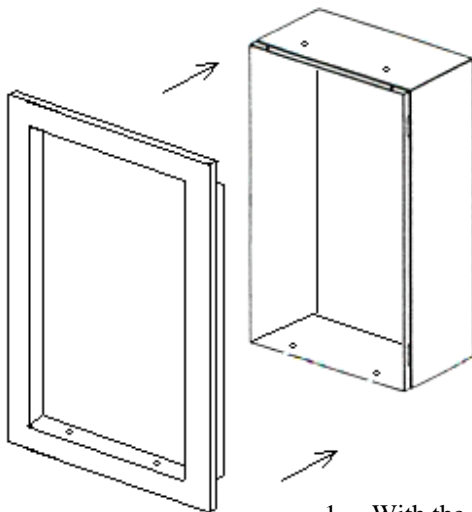

## Installing the Flush Door Trim

Prior to installing Door Trim, ensure that wall finishes are complete and that the door panel has been installed.

To install the Flush Door Trim:

1. With the door in the open position, slide flush door trim over enclosure.
2. Align holes on enclosure with upper and lower holes in door trim.
3. Insert four (4) 8-32 (provided) screws through enclosure panel and tighten into door trim.

**Note:** Apply Sealant/Adhesive to trim screws at surface of Enclosure at each mounting hole for all Air Tight and Air Tight with Vent Enclosures.

## **Operation of the Unit:**

### **Keep the enclosure's door closed and locked during normal operation.**

Insert the key provided with the unit into the key switch on the door panel. With the panel service switch(s) ON, engage the key switch. The unit will activate and the panel Green LED(s) will illuminate to indicate that the service(s) is active.

After turning the switch OFF, it will be necessary to re-engage the key switch in order to reactivate the service.

Pressing the panic button will deactivate the service, requiring re-engagement of the key switch to again reactivate service. The RED Led(s) will illuminate when the unit is in "Panic".

We recommend that the door panel switches be left in the OFF position when service is not required. For Dual Output Units (two switches on the door panel) a second controlled device will be located remotely from this unit. The door panel switches are labeled according to their function.

Where an output monitoring circuit is incorporated into the system, upon pressing the Panic Button this circuit closes thus sending a notification of "Panic" signal that can be registered by automation systems such as a Building Alarm System. Dual output circuit units feature an optional time delay notification circuit that is settable from 0 to 5 minutes.

Additionally, the unit incorporates input circuits that can register an input signal from a fire alarm system, thus disabling the unit in the event of an active fire alarm. Terminals are also provided for a remotely located additional panic button.

## **Equipment Maintenance**

- ❑ The LSP (Laboratory Service Panel) should have semi-annual inspections.
- ❑ *ISIMET* recommends turning OFF the internal service switch when the unit is not intended for operation.
- ❑ *ISIMET* recommends that you periodically conduct a brief test of the system to verify that the output and monitoring circuits perform as intended.
- ❑ If examination of the unit indicates tampering, *ISIMET* recommends that you first review the installation and wiring portions of this manual prior to placing the unit in service.
- ❑ *ISIMET* recommends that when solenoids are operated by the unit that the piping systems be thoroughly flushed and cleaned, and tested for leaks prior to placing the system in use. Periodic testing of these solenoids will assure that the piping system continues to function properly.

If you have any questions regarding the operation and maintenance of the Service Panel, please contact an *ISIMET* Service Representative.

## **Care of the Unit**

The enclosure has a NEMA 1 rating. It is not intended for use in wet areas. Exercise caution to prevent exposure of the interior compartment of the enclosure to moisture. If moisture is present within the enclosure, *ISIMET* recommends that the control switch be turned OFF, power be disconnected from the unit until the source of the moisture is determined, and all moisture is removed from the compartment.

The electronic controller (PCB) is sensitive to dust and other air-borne particles. Do not expose the interior compartment of the enclosure to dust. During the semi-annual inspection, if dust or other material is present, *ISIMET* recommends that you remove all foreign matter before operating the unit.

If the Unit fails to operate, we recommend that you check the power supply to the unit. With the control switch in the ON position, it should be illuminated if power is on to the unit. If not, check the service breaker.

If the control switch is illuminated, check the fuse at fuse holder. If the fuse is not damaged, and the unit still does not function, contact *ISIMET* or your local Service Representative.

If the unit still fails to operate, we recommend that you contact your local Service Representative

Note: It is not uncommon upon power-ON for the unit to go to the "Panic" state, transmitting a notification signal. If this occurs, using the key switch, reset the unit to OFF.

**CAUTION:**

**ISIMET DOES NOT** recommend that service to emergency and/or safety devices, such as emergency showers and eyewashes, be controlled by the Service Panel or Solenoids. Such devices are intended to operate independent of restrictive authority operation as is the case with the design of this unit. **ISIMET** makes available components for the monitoring of such safety devices. Please contact **ISIMET** regarding any questions regarding this type of application.

**ISIMET** believes that sole and local authority means that the primary operator or the instructors should have the sole authority to start and stop the utility services within the immediate area of use during normal usage. This should distinguish this type of operating environment from that where a single emergency shut-down device is located remotely from the areas of use. As an example, the **ISIMET** system is not specifically intended for use in applications where a master shut-down and re-instate device is located away from areas of normal use. **ISIMET's** opinion is that in such cases there is risk that the operator of the system during re-start may inadvertently activate utilities in an unoccupied area that is remote from the present occupancy, thus creating the risk of fire or where the utility is fuel gas.

**Caution:**

Pressure testing for fuel gas system solenoids should not exceed 15 psi at the body of this valve due to potential damage caused by excessive pressure applied to the diaphragm.

Coils should not be energized unless secured to the valve core. Coils will heat during operation. A temperature of  $\pm 150^{\circ}$  is not uncommon.

General Service Solenoids: Where adverse or harsh operating conditions exists in the water system such as the presence of hard water, then it is recommended that only stainless steel valves be utilized and that an extensive routine operating and maintenance program be developed by the end user to counter the effects of these conditions. Where operation of water containing corrosive agents, exotic or harsh mediums are intended for control by solenoid then verify application prior to installation. **ISIMET** cannot warrant against the effects of hard water, corrosive agents, contaminants, or debris present in the piping system or against effects of exotic or harsh substances. If specific operating conditions are in doubt, contact **ISIMET** prior to installation.



**103 W. CJ Wise Parkway  
PO Box 129 (Mailing)  
Naples, TX 75568**

**Phone (866) 897-0737  
Fax (903) 897-0740**

**[www.ISIMET.com](http://www.ISIMET.com)**