

ISIMET

ITC 100 – Panel Style

Integration Interrupt and Time Control Device

Installation Instructions

ISIMET

103 C.J. Wise Parkway
Naples, TX 75568
(903) 897-0737
(903) 897-0740 fax

Copyright © 2010 ISIMET, LLC.
All rights reserved.

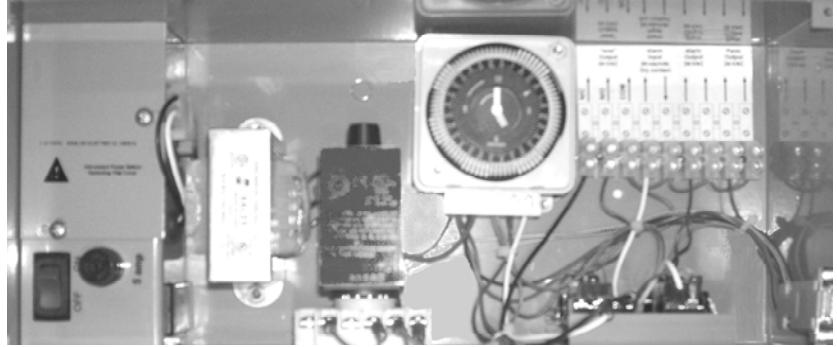

The ISIMET Time Control Unit provides the time sequencing feature common to systems that are integrated with a building automation or management system “ems”. Similar to those systems, this unit includes a 7-day time switch that can be set to specific timing “ON” and “OFF” periods of operation. The unit should be located in an area not accessible to normal classroom activity.

Model 110: Surface Mount with Gray PC Wall Panel

Model 120: Flush Mount with Stainless Steel Wall Panel

Features:

- Operation Switch: Panel Mounted key Switch permits system to be turned OFF for maintenance purposes. Panel mounted “GREEN” indicator lamp indicates that system is operational.
- Over-ride Switch: A panel mounted momentary key-switch interrupts the timing “OFF” sequence for a settable period from 30 – 120 minutes (5% toL). “ems” / Over-ride Circuit is provided with a “ORANGE” indicator lamp.
- Alarm-IN Hub: A common input point for integration with a building alarm system that permits input integration from that system for a series of ISIMET Control Systems to occur at a single point. N/O. Circuit is provided with a RED Indicator.
- PANIC Button: Requires PULLING the panic button back out to reset the Time Control Unit before operation is restored at individual ISIMET Controllers. Circuit is provided with an “RED” indicator lamp.
- Interface HUB: A terminal strip is provided within the enclosure to facilitate field provided wiring terminations between the ISIMET Control Systems and integrated automation systems such as “ems” and/or Building Alarm.
- “ems” HUB: (Optional feature) Omitting the Timer and providing an input hub for an “ems” signal permits a single “ems” signal to be distributed to each of a group of Controllers.

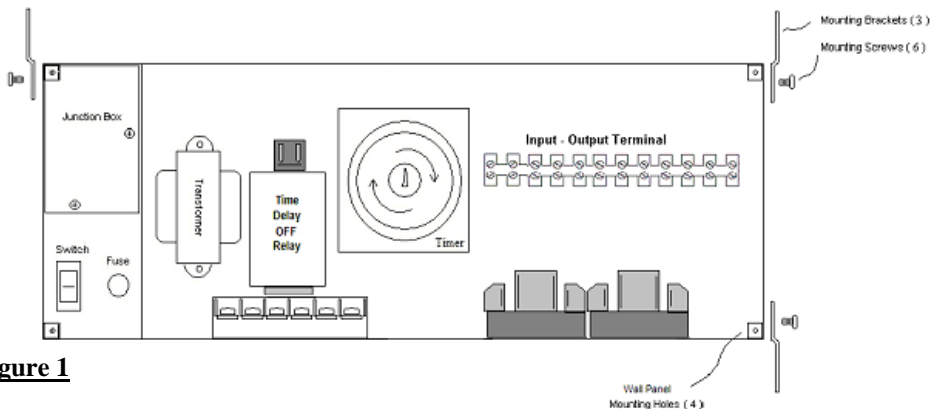

Figure 1

Surface Mounted Units

Units intended to be surface mounted are provided with four (4) flanges. The back of the enclosure can be drilled to accept the mounting flange hardware at each rear corner.

Important!

All local electrical codes must be followed when connecting the conduit to the service panel and making wiring connections.

Do not install wiring or cable for integrated systems, remote panic assemblies or other interface wiring within conduit for either 24-vac control or 120-vac line voltage. Each wiring system should be housed in independent conduit and not bundled with wiring for other systems.

Mounting the Wall Box:

Using the provided mounting brackets and screws, secure the unit to a structural member. The unit should be mounted in a location convenient for maintenance so that adjustments to the delay setting are convenient. After mounting and installation of interconnect cabling, we recommend that the cover be placed over the box opening to prevent debris from potentially damaging the unit.

Enclosure Dimensions: 6.0” X 13.875” X 4”

Service Requirements:	Output Circuit Voltage Rating:
120/60 vac; 5 amp fuse Min. 14 AWG	Transformer 24 vac 2 Amps

Installing the Electrical Conduit

Knockout holes for connecting the electrical conduits are located at the top left and right of the Wall Box.

- Connect rigid conduit for the required 120-vac electrical service.
- Connect conduit for the operating power to the upper left top of the enclosure at the junction box.
- Connect conduits for the 24-vac Input - Output to the upper right top of the enclosure.

CAUTION: Input-Output signal wiring should not be routed within conduit with 120-vac line wiring.

Wiring the Unit

Important!

Verify that the electrical supply is disconnected prior to connecting wiring to the Unit.

To wire the Controller:

1. Remove the junction box cover.
2. Make final connections to the 120-vac electrical service to wiring within the junction box. Verify that line wiring (Black), neutral (White), and ground wire (Green) are correctly connected.
3. Minimum recommended wire size is 14 AWG.
4. Replace the junction box cover before activating or testing the unit.

CAUTION: DO NOT route wiring from this device to the Utility Controller within conduit containing either 120-vac line or 24-vac output control wiring. Alarm Input wiring should not be housed in conduit with other wiring.

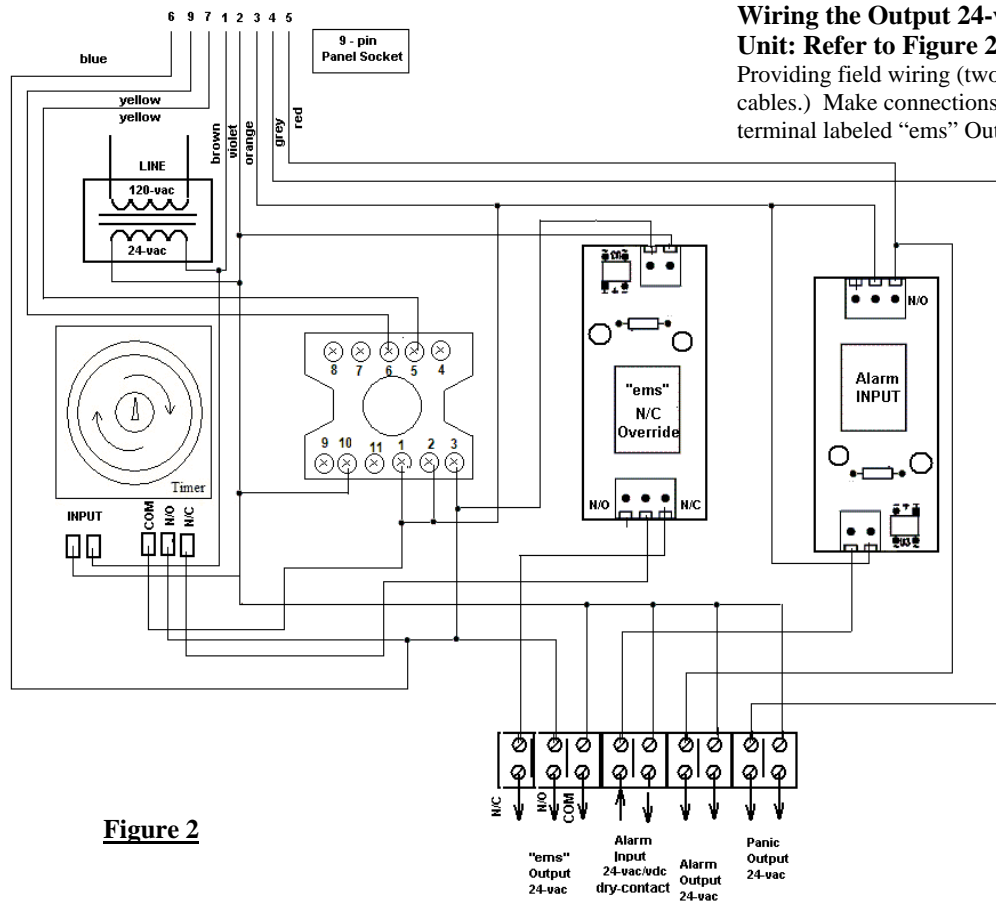

Wiring the Output 24-vac Control Signal to the Unit: Refer to Figure 2

Providing field wiring (two 2 conductor -18 AWG max cables.) Make connections as shown in figure to two post terminal labeled "ems" Output.

Figure 2

NOTE: Where used with LA and LSP Controller the "ems" output signal is normally inactive rather than normally active. Those units should be field connected to the N/C and COM rather than N/O and COM terminal at the "ems" Output Relay.

Wiring Input – Output Alarm Wiring

If the unit is used as a HUB receptor for an Input Alarm signal for shut-down of the integrated Utility Controllers, then make connections from the Alarm Input Terminals to the contact points on a standard Alarm Interface Relay. When an alarm Signal energizes the module, that contact closes, activating the Alarm Circuit on this unit. Connect 18 AWG (max) output wiring to each Controller from the “Alarm Output” Terminal.

Wiring Output Panic Wiring

If the unit is used as a Master Output “Panic” Control for Output of Panic to shut-down the integrated Utility Controllers, connect 18 AWG (max) output wiring to each Controller from the “Panic Output” Terminal.

Wiring connection is made at the Controller’s auxiliary Panic Input terminal.

TIME SETTING

To set the current time and day of week, turn the minute hand clockwise until the day of the week and the time of day on the outer dial is aligned with the triangle marker on the inner dial. DO NOT set the time by rotating the “OUTER” Dial.

The weekly program dial reflects the seven days of the week and AM/PM imprints for each day.

PROGRAMMING the TIMER

The time switch is programmed by pushing the captive trippers to the outer ring position for the entire period that the “ems” output signal is to be turned “ON” in 2-hour increments. When the tripper is pushed to the inside, “ems” signal is “OFF”.

Example: Set the trippers for each normal classroom day (Monday – Friday) to the “ON” position for the period from 8:00 AM until 4:00 PM. The Utility Controllers integrated with the unit will be enabled only during this time period. The Timer is Factory set for Monday through Friday; 8:00 AM to 4:00 PM.

Wall Panel Features:

The panel is provided with a maintained “**Operate**” key switch with a Green lamp to indicate that the unit is operational. The power supply for the Time Switch, if provided with the unit, is a by-pass of this switch. No functions of the system will operate if this switch is in the “OFF” position.

“ems” Over-ride

A momentary key switch enables after hours or “non-ems” signal operation of the integrated Utility Controllers by starting a N/O time delay “OFF” relay. A Orange lamp indicates that an “ems” signal is transmitting to the Controllers and that those Controllers are operational. This indicator illuminates whether the “ems” signal is transmitted automatically or by the over-ride key switch. Time setting for this over-ride is made internally. The adjustment knob located on the Timing Relay Setting is from 30 – 120 min.

Time Delay “OFF” Settings:

Timing Relay Setting is from 30 – 120 min. with a factory setting of 1 hr. The relay may be set for any interval between 0 and 2 hrs. Other re-programming features are available for the relay, but it is not recommended that field adjustments other than those stated here be made. Please contact ISIMET if changes to other relay settings are desired. To adjust time delay setting, remove the Controller cover, turn “OFF” power to the unit. Adjust the knob on top of the relay to the appropriate setting. Replace cover.

Note:

Panic Button

A maintained RED Panic button will transmit a “panic” signal to each integrated Utility Controller. Because this switch requires a key-reset, the Controllers will remain inoperable until key reset. A Red lamp illuminates to indicate that the unit has an active “panic” output signal.

Alarm Input Signal

A Red lamp illuminates upon an active Alarm Input signal from that system. Integrated Utility Controllers are disabled until the Alarm signal is withdrawn.

Installing the Wall Panel

- Remove any protective cover previously placed over the face of the Wall Box.
- Insert the wall panel plug into the socket. The plug is a polarized 9-pin connector. The socket is mounted onto the left side of the wall box as shown in figure 1.
- Affix panel to box using four (4) 8-32 stainless screws provided with panel.

Note: The unit is provided with either a gray powder coat panel for surface mounting or a brushed stainless steel panel for flush mounting. Verify that the wall box installation conforms with the provided wall panel.

CAUTION! Do not install the panel until all wall finishes are complete

Test the Unit:

We recommend that you test the various function of this unit to verify that all features perform as stated here. Also, periodic re-testing to determine component failure or loss of integration with the Controllers or other automation systems such as “ems” or alarm is recommended.

If the unit fails to operate, contact *ISIMET* or a factory representative.

Operation of the Unit:

The *ISIMET* Time Control Unit provides for a centrally located control HUB for time sequence operation of a series of *ISIMET* Utility Controllers (ten MAX.). If the unit is provided with a Timer Switch, then settings are made within the unit to determine normal or usual operating hours of the integrated Utility Controllers within each science classroom. A Master "ON" key switch activates the unit. The internal timer's power supply bypasses this switch so as to permit shutdown of operation without violating the pre-set timer.

The over-ride key switch permits a supervisor and/or user to enable the integrated Utility Controllers that were disabled due to loss of an "ems" (energy management system) signal. The ORANGE indicator acknowledges that an "ems" signal is transmitting to the Controllers. The two keys, as well as the "Panic" reset key, are keyed alike and it is recommended that they be kept in a secure location.

If the unit uses an automation signal from an energy management system "ems", then the over-ride feature will provide the enabling signal for after hours operation of the integrated Controllers.

The over-ride "ems" circuit is set internally for a period from 30 – 120 minutes. Keying of this over-ride switch will start the timing cycle even during a pre-existing over-ride cycle period.

The Panic Switch (A maintained red mushroom button) permits a supervisor or other person of authority to manually shut-down all integrated Utility Controllers in the event of a perceived emergency. Controllers disabled due to receipt of a "Panic" signal from this unit will remain disabled until the Panic Button has been reset by pulling out the button. An RED light indicates that a Panic signal is transmitting.

An Alarm HUB circuit is provided whereby an alarm signal transmitted by that system to this unit will be re-directed to each of the integrated Controllers. A Red light indicates that an Alarm signal is detected.

Warranty:

***ISIMET* will repair or replace any defective parts or workmanship of this product for a period of one year from date of installation. Damage caused by incorrect installation or improper usage is not warranted. Failure to follow recommended installation, operation, and/or maintenance procedures listed in this manual may void product warranty. Recovery rights shall be limited to the total sum of the amounts paid for the product by the purchaser.**

Limits of Liability:

***ISIMET's* liability shall be limited to costs of repair or replacement parts. This unit is not intended for usage other than those expressly described in this manual. *ISIMET* shall not be liable for damage or injury caused by the improper use of the product.**

***ISIMET* shall not warrant against or assume liability for failure of operation or lack of notification to secondary integrated monitoring systems. The system should be thoroughly tested and adjustments made at time of initial operation. Periodic testing should be conducted by the user to assure that all components function and operate according to specifications.**

Care should be taken in the installation of this product. *ISIMET* shall not be liable for damage or injury caused from the improper installation of the product.

DISCLAIMER OR IMPLIED WARRANTY:

THERE ARE NO WARRANTIES THAT EXTEND BEYOND THE DESCRIPTION HEREIN. SELLER DISCLAIMS ANY IMPLIED WARRANTY OF MERCHANTABILITY OF THE GOODS OR OF THE FITNESS OF THE GOODS FOR ANY PURPOSE, AND BUYER AGREES THAT THE GOODS ARE SOLD "AS IS."

Warranty is Subject to Compliance with Specific Installation Requirements.

This document is copyrighted. This document may not, in whole or part, be copied, duplicated, reproduced, translated, electronically stored, or reduced to machine readable form without prior written consent from *ISIMET*, LLC.

Although the material contained herein has been carefully reviewed, *ISIMET*, LLC does not warrant it to be free of errors or omissions. *ISIMET* reserves the right to make corrections, updates, revisions, or changes to the information contained herein.

ISIMET is a trademark of *ISIMET*, LLC

Printed in the United States of America