

ISIMET LP1

Science Lab Utility Safety Package Installation Manual



ISIMET LP1
Installation Manual

Copyright © 2018 ***ISIMET/MAPA, LLC***. All rights reserved.
Patent 6,757,589 B1, 6,990,393 B2, 8,543,225, Other Patents Pending

This document is copyrighted. This document may not, in whole or part, be copied, duplicated, reproduced, translated, electronically stored, or reduced to machine readable form without prior written consent from ***ISIMET***.

Although the material contained herein has been carefully reviewed, ***ISIMET*** does not warrant it to be free of errors or omissions. ***ISIMET*** reserves the right to make corrections, updates, revisions, or changes to the information contained herein.

ISIMET is a trademark of ***ISIMET/MAPA, LLC***, an affiliate of ***WCM Industries, Inc.***

Printed in the United States of America.

Table of Contents

ISIMET LP1 -Science Lab Utility Safety Package	4
Important Warnings.....	4
Parts List.....	5
Utility Controller.....	5
Gas and Water Solenoid Panel.....	5
Electrical Panel	5
Panic Button.....	5
Fuel Gas Sensor	5
Emergency Shower Monitor	5
Monitoring Beacon	5
Mounting the LP1.....	6
Mounting the Utility Controller (UtC).....	6
Mounting the S-Series Enclosure.....	9
Mounting the E-Series Enclosure.....	10
Mounting the Panic Button.....	11
Mounting the Fuel Gas Sensor.....	12
Mounting the Monitoring Beacon	12
Mounting the Emergency Shower Monitor	12
Electrical Conduit Installation	13
S-Series Gas and Water Piping Installation	14
Wiring the LP1 System	15
UtC Control Panel.....	15
S-Series.....	16
E-Series and Exhaust Fan	17
Panic Button(s).....	20
Fuel Gas Sensor	21
Emergency Shower Monitor	22
Monitoring Beacon	23
Gas Pressure Transmitter (Optional)	24
Building Fire Alarm (Optional)	25
Building Energy Management System-EMS/BMS (Optional)	25

Hardware Configuration Settings (Jumpers).....	26
Connecting Power to the UtC	27
Installing the UtC and S-Series Trim Plate.....	28
Installing Covers	28
Installing UtC Door Panel	29
UtC Fuse Specifications	30
Acronyms and Common Terms.....	30
Control Panel Terminal Definitions.....	31
Gas Pressure Transmitter	31
Miscellaneous	31

ISIMET LP1 -Science Lab Utility Safety Package

Providing ultimate authority and control over a laboratory utility system to authorized personnel. At any time, natural gas, water, and electrical can be de-activated by use of a Panic Button, Building Fire Alarm System, Building Energy Management System (EMS), and/or programmable controls.

Key Features:

- Controls gas, electric, water, and exhaust fan
- Key-activated system prevents unauthorized use
- Code compliant, plus additional safety features
- Programmable timer automatically turns off utilities
- Panic Button turns fan on to exhaust room; fire alarm turns fan off
- Helps keep personnel and facilities safe



Important Warnings

Indoor Storage and Installation:

Installers shall be responsible for protecting the control panel, solenoids, and electrical enclosures from rain, liquids, construction and drywall debris and materials, dust, and extreme heat or cold (above 90°F and below 32 F°). Such exposure may result in equipment failure.

Preventing Transient Voltage:

Control wiring **MUST** be housed in separate conduit from power wire (120VAC, 24VAC, or 12VDC).

Codes and Experience:

Only qualified, licensed plumbers and electricians within the governing jurisdiction should perform this installation and/or service this equipment.

All ADA, local plumbing, and national electrical codes must be followed.

Parts List

See Appendix for complete Parts List

Utility Controller

- 1x UtC Enclosure
- 1x UtC Door Panel
- 1x UtC Trim Plate
- 14x Wiring Labels
- 2x Flush Mount Brackets
- 2x Surface Mount Brackets
- 8x #8 x 1/2" Self-Tapping Screws
- 1x PN: 15003 PCB

Gas and Water Solenoid Panel

- 1x S-Series Enclosure
- 1x S-Series Trim Plate
- 2x Mounting Brackets
- 8x #12 x 1/2" Self-Tapping Screws
- 6x Rubber Grommets

Electrical Panel

- 1x E-Series Enclosure
- 1x Eaton C30CN Electrical Contactor
- 6x 2-Pole NO/NC Contactors

- 1x RIBMN24S Relay
- 1x RIBMN24C Relay

Panic Button

- 1x 5x5x3 J-Box
- 1x Panic Button

Fuel Gas Sensor

- 1x 5x5x3 J-Box
- 1x Fuel Gas Sensor
- 1x 3/8" Rubber Grommet
- 1x PN: 4986 PCB

Emergency Shower Monitor

- 1x 5x5x3 J-Box
- 1x Flow Switch
- 1x PN: 5014 PCB

Monitoring Beacon

- 1x 5x5x3 J-Box
- 1x ISIMET Monitoring Beacon

Mounting the LP1

Mounting the Utility Controller (UtC)

There are two options for mounting the Utility Controller: Flush Mount and Surface Mount. Skip to the required section for installation instructions.

Flush Mount Installation (Recommended)

1. Remove the cardboard protective cover from the UtC and save for later reinstallation.

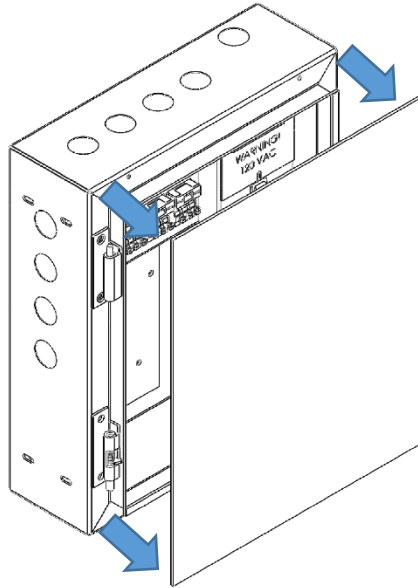

NOTE: Be sure to save and reinstall the cardboard protective covering after installing the UtC to protect the electronics from damage during drywall/wall finishing!

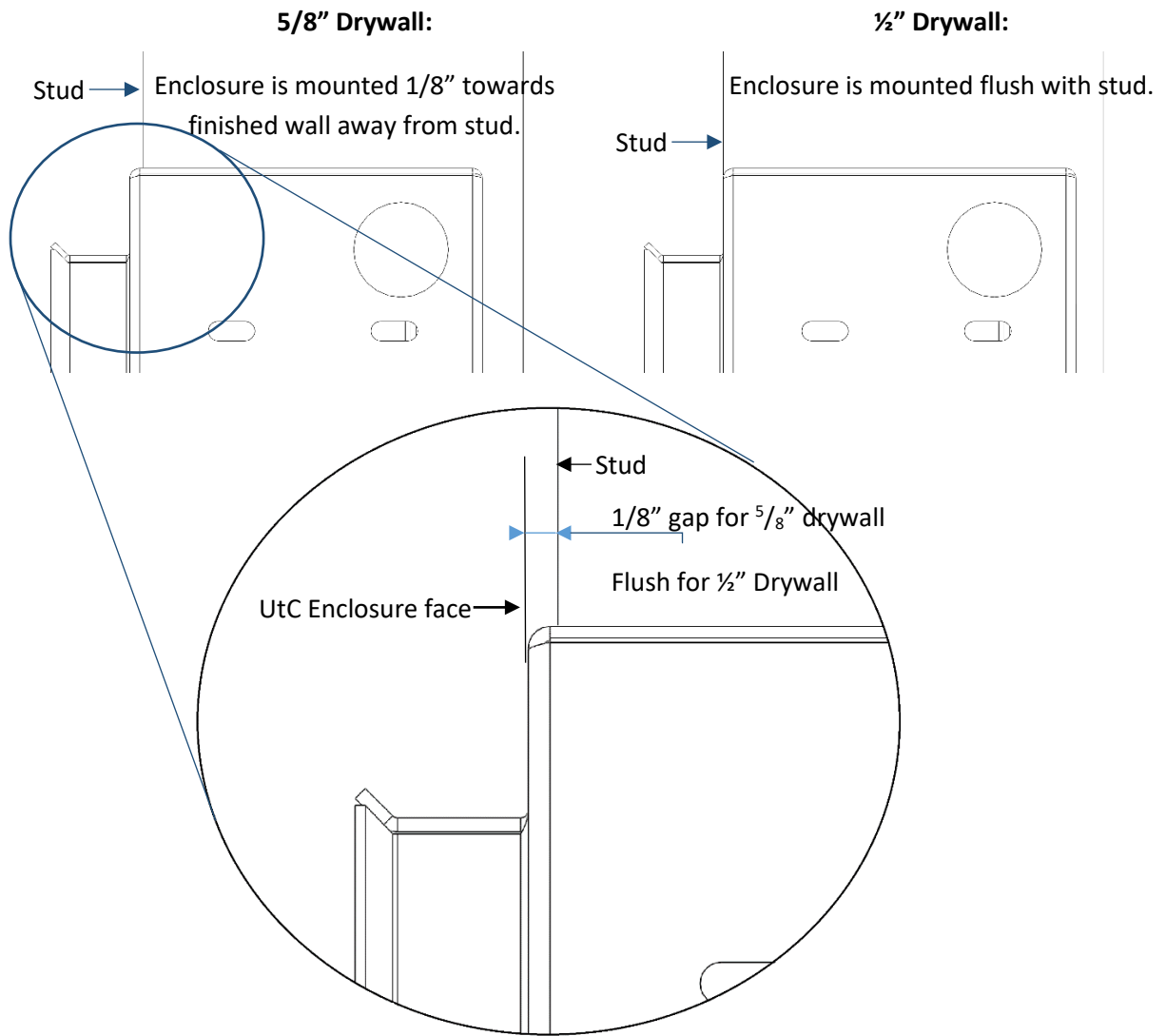

2. Place the UtC Enclosure next to the stud allowing for finished wall clearance. (This can be slightly adjusted after installation by loosening the mounting screws shown in the next step, adjusting, and then re-tightening.)

3. Level and secure the UtC Enclosure to the stud using appropriate mounting screws.

Ensure that the mounting screws are centered to allow for minor adjustments, if needed, after the trim plate is installed.

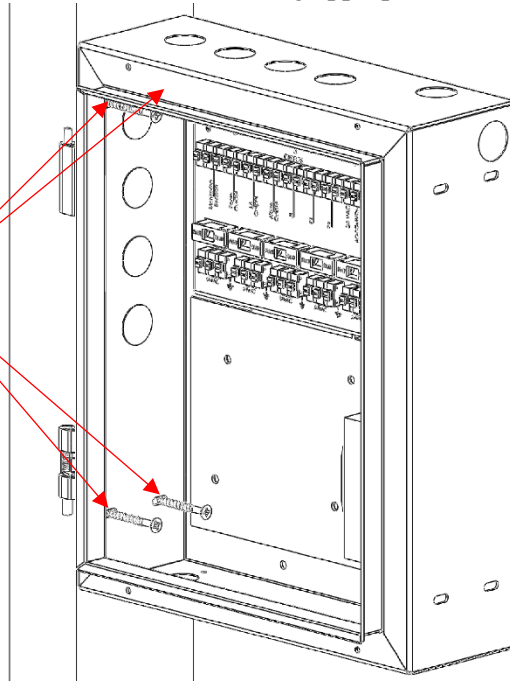

4. The UtC must have a 1/2" gap around the enclosure when installing the finished wall to accommodate the metal Trim Plate.

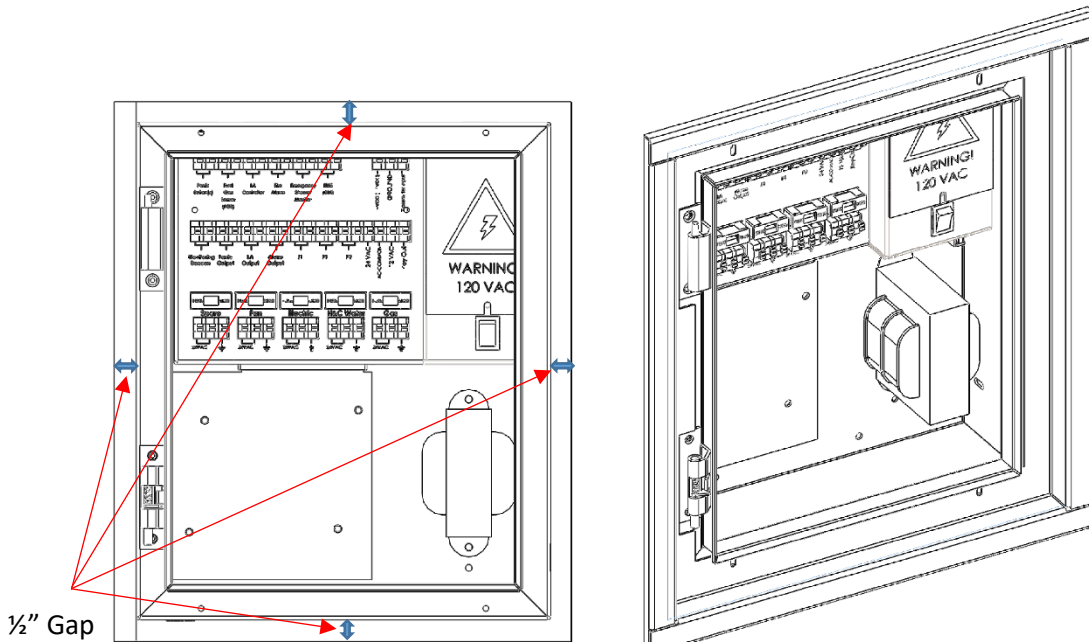

Between UtC Enclosure and Finished Wall

UtC with Trim Plate Installed (After finished wall)

Mounting the S-Series Enclosure

The E- and S-Series Enclosures should be mounted where they are easily accessible. It is recommended to install the water lines with Shock/Water Hammer Arrestors.

(S-Series) Flush Mount Installation (Recommended)

1. Attach the included (2)-Brackets and (4)-#12 Self-Tapping Screws to either the left or right side of the S-Series Enclosure.

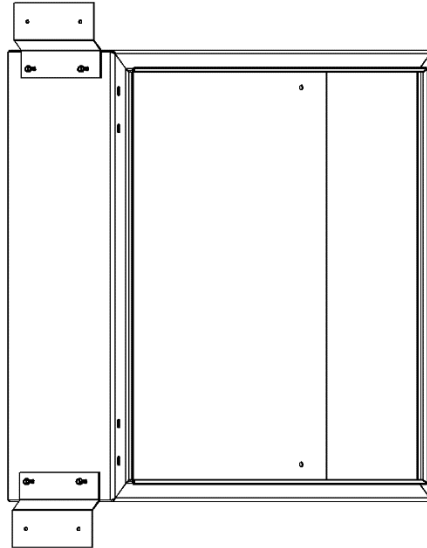

2. Trial fit the included S-Series Trim Plate and mark the Enclosure where the holes are needed for proper fitment.
3. Verify clearance and possible obstructions before drilling these Trim Plate holes into the S-Series Enclosure
4. Level and secure the enclosure to the stud using appropriate screws (not included).

(S-Series) Above Ceiling Installation

1. Threaded rod, strut, and/or other methods can be used to install the S-Series Enclosure.
2. Adjust and align the solenoids in the S-Series Enclosure
 - a. The solenoids should be orientated so the coils are facing away from the ground.
 - b. Loosen the universal joints.
 - c. Adjust the Y Strainer (if applicable) to point towards the ground.
 - d. Adjust the solenoid coils away from the ground.
 - e. Adjust the shut-off valve so it is operable.

(S-Series) Surface Mount Installation

1. Ensure wall has sufficient support
2. Level and secure the S-Series Enclosure through the predrilled holes using appropriate screws (not included).

Mounting the E-Series Enclosure

(E-Series) Surface Mount Installation (Recommended)

1. Ensure wall has sufficient support
2. Level and secure the E-Series Enclosure through the predrilled holes using appropriate mounting screws.

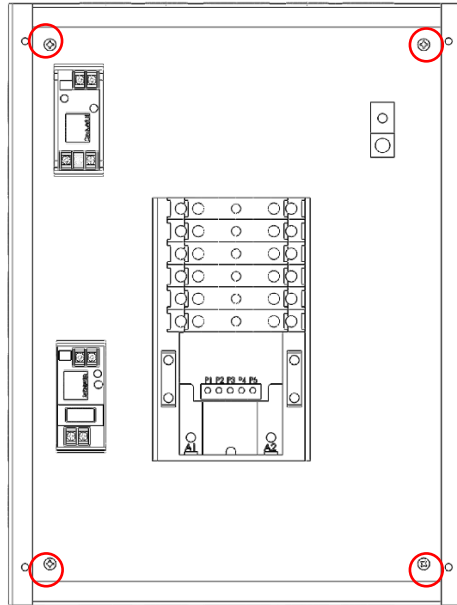

(E-Series) Semi-Recessed

1. Mark and drill (4) mounting holes at the corners of the E-Series Enclosure avoiding any components and/or obstructions.
2. Level and secure the enclosure to the stud using appropriate mounting screws leaving enough room for the included cover to be installed after the finished wall is installed.

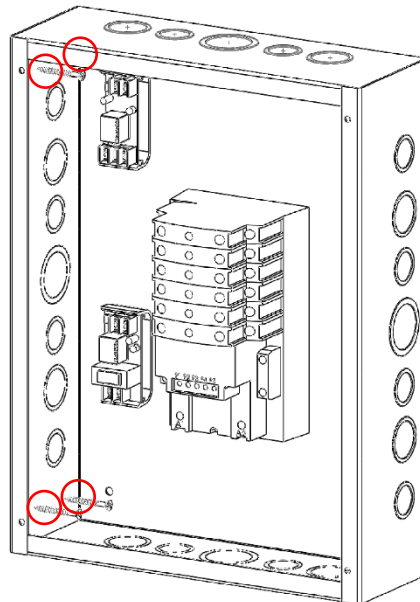

Mounting the Panic Button

Semi-Recessed/Flush Mount Installation

1. Place the included junction box against the stud allowing for the finished depth (drywall thickness).
2. Secure the included junction box to the studs through the predrilled holes using appropriate screws (not included).

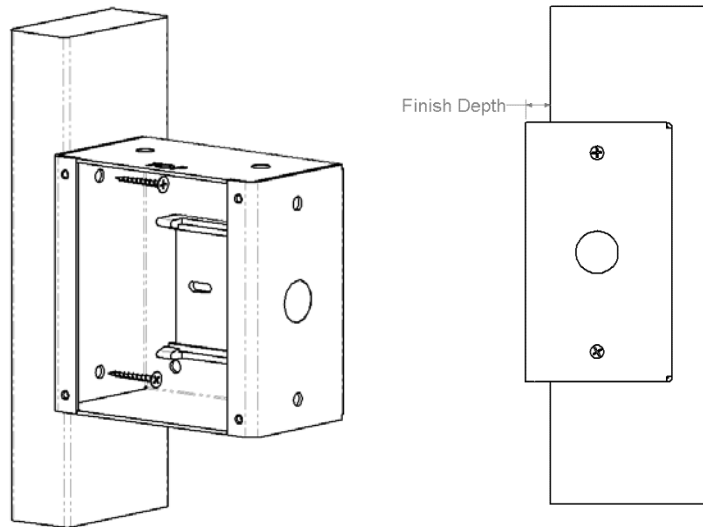

Surface Mount Installation

1. Ensure wall has sufficient support
2. Place and level the junction box against the wall.
3. Secure the junction box through the predrilled holes using appropriate screws (not included).

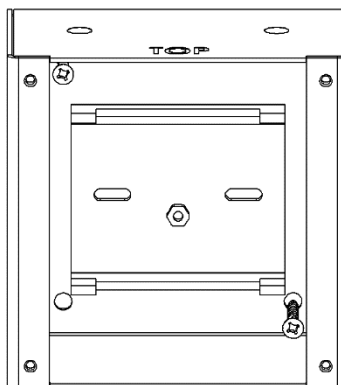

Mounting the Fuel Gas Sensor

- The FGS should be mounted dependent on the type of gas being detected.
 - Natural Gas (Default): Install 12-14” from the ceiling in an area with the most air movement and highest likelihood of detecting natural gas.
 - Propane: Install 12-14” from the floor in an area with the most air movement and highest likelihood of detecting propane.
- Follow the same steps as shown in Mounting the Panic Button.

Mounting the Monitoring Beacon

- The Monitoring Beacon should be mounted in a location that is readily visible to laboratory/supervisory personnel.
 - Typical installation location is outside of the laboratory at the top of the doorway.
- Follow the same steps as shown in Mounting the Panic Button.

Mounting the Emergency Shower Monitor

- The Emergency Shower Monitor must be installed to accommodate the 24-inch (60.96-cm) flow switch cable provided.
- The flow switch is intended to be installed in a TEE directly upstream in the supply line to the emergency shower.
- **Caution: Use of a TEE with a threaded adapter and/or bushing reducer may not be suited for this application and may restrict the flow switch’s ability to monitor the EM Shower. Always test the system after completing installation.**
- Follow the same steps as shown in Mounting the Panic Button.

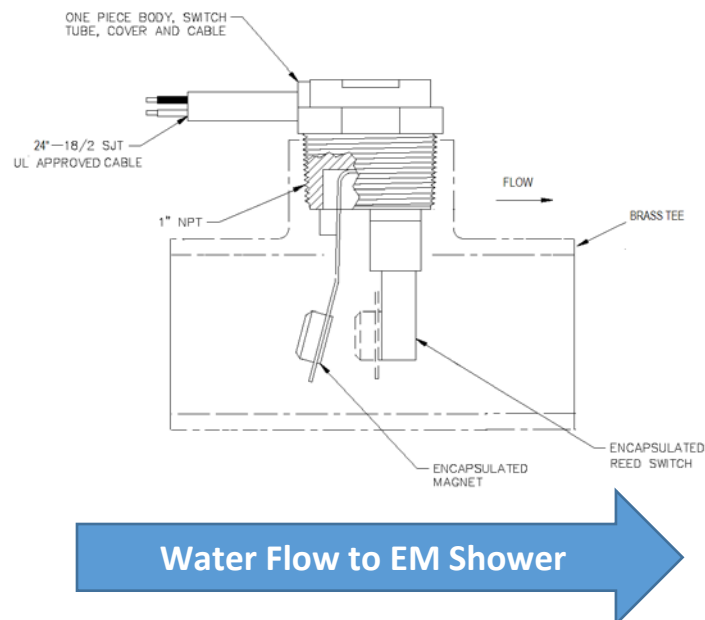

Electrical Conduit Installation

A licensed electrical contractor should perform this step following all electrical codes and procedures.

1. Remove the required knockouts to the UtC. (Either TOP or LEFT and RIGHT Configuration)

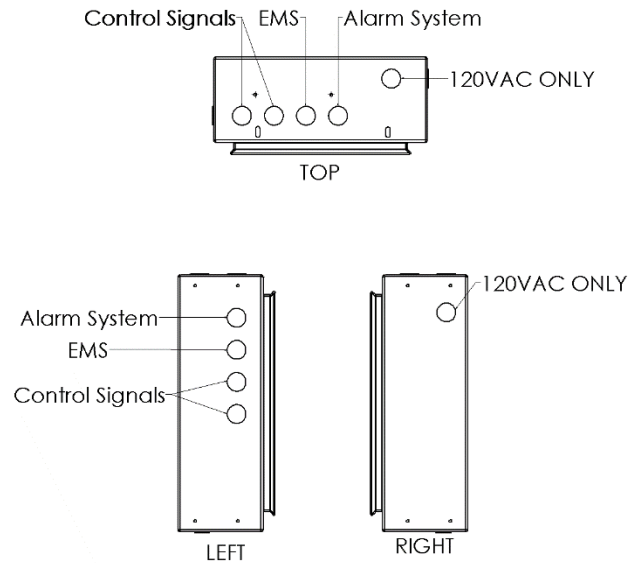

It is recommended to install all control wiring in separate conduit as follows:

Wires That Can go in Same Conduit	
Outputs (24 VAC)	Gas Solenoid Control Wiring Water Solenoids Control Wiring Electrical Outlets Control Wiring Exhaust Fan Control Wiring Beacon Control Wiring
Inputs (24 VAC)	EMS Panic Button(s) Emergency Shower
Must be In Separate Conduit	Alarm

If, however, conduit is not used, separate these control signals from each other as much as possible (minimum 2") to prevent transient/induced voltages.

Electrical Metallic Tubing (EMT) should be used to separate these control signals from the 120VAC.

ISIMET LP-1
Example Installation

Notes:
Control Wiring must be a minimum of 18/4 Shielded Wiring(18AWG with 4 conductors).

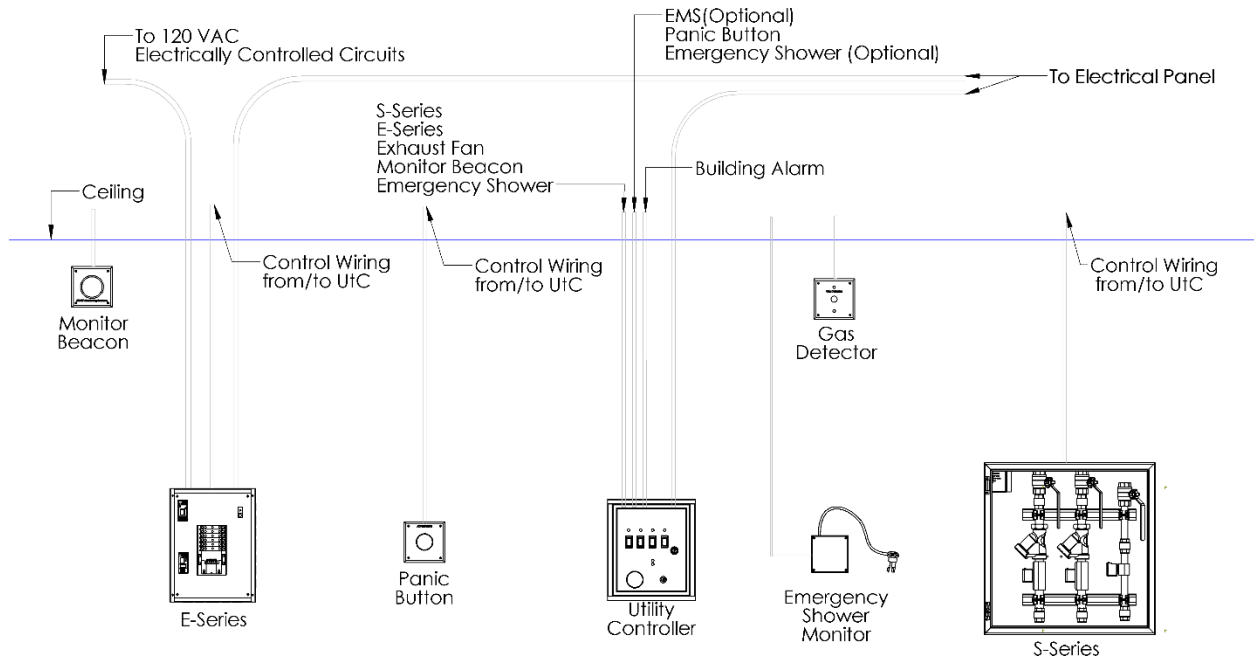

S-Series Gas and Water Piping Installation

A licensed plumber and/or pipe fitter should perform this step following all national and local codes and procedures.

1. Ensure the S-Series Enclosure is installed in a location that is readily accessible.
2. It is recommended to flush the pipes to prevent leakage or blockages.
3. Install the piping for the hot and cold water using the included rubber grommets to enter the S-Series Enclosure. Be sure to install the piping with the correct orientation following the flow shown on stickers inside the enclosure.
4. Install the piping for the gas line using the appropriate pipe diameter and following all national and local codes.

Wiring the LP1 System

The LP1 System utilizes 24VAC as a standard.

Normally Closed (NC) Solenoids are used to prevent operation during power loss

- Use **ONLY** with ISIMET approved products.
- Turn **OFF** the service switch **PRIOR** to any wire connections.
- **#18 AWG shielded wire** should be used for all control wiring
- All shielding should be grounded to  of the UtC Control Panel
- Remove and store all protective coverings for reinstallation after wiring

UtC Control Panel

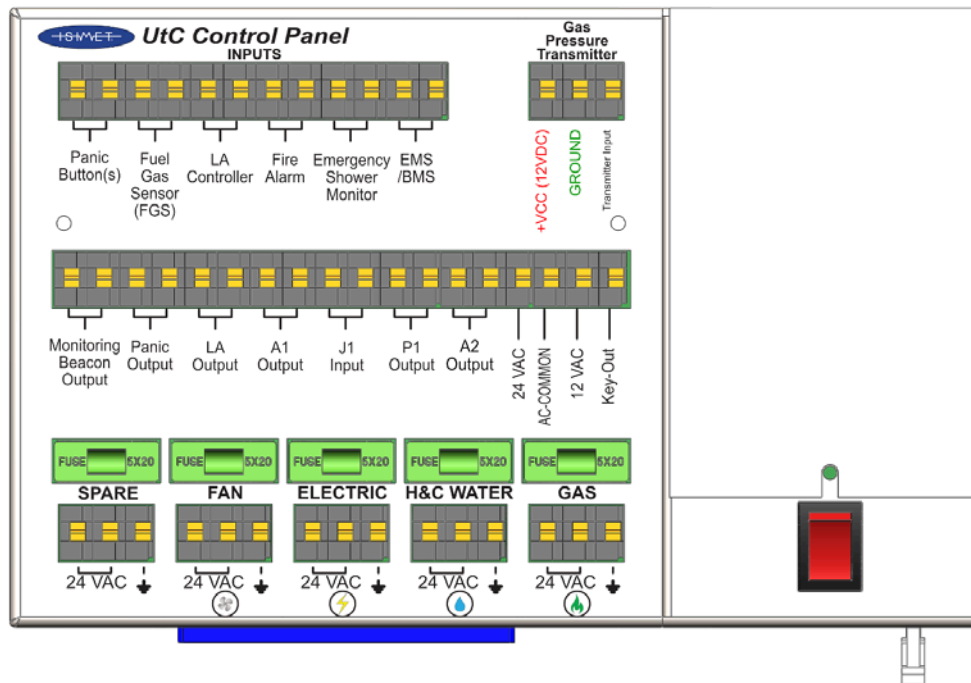

See Control Panel Terminal Definitions in the appendix.

Note: Polarity does NOT matter for control wiring unless explicitly called out in this instruction set.

S-Series

UtC Control Panel

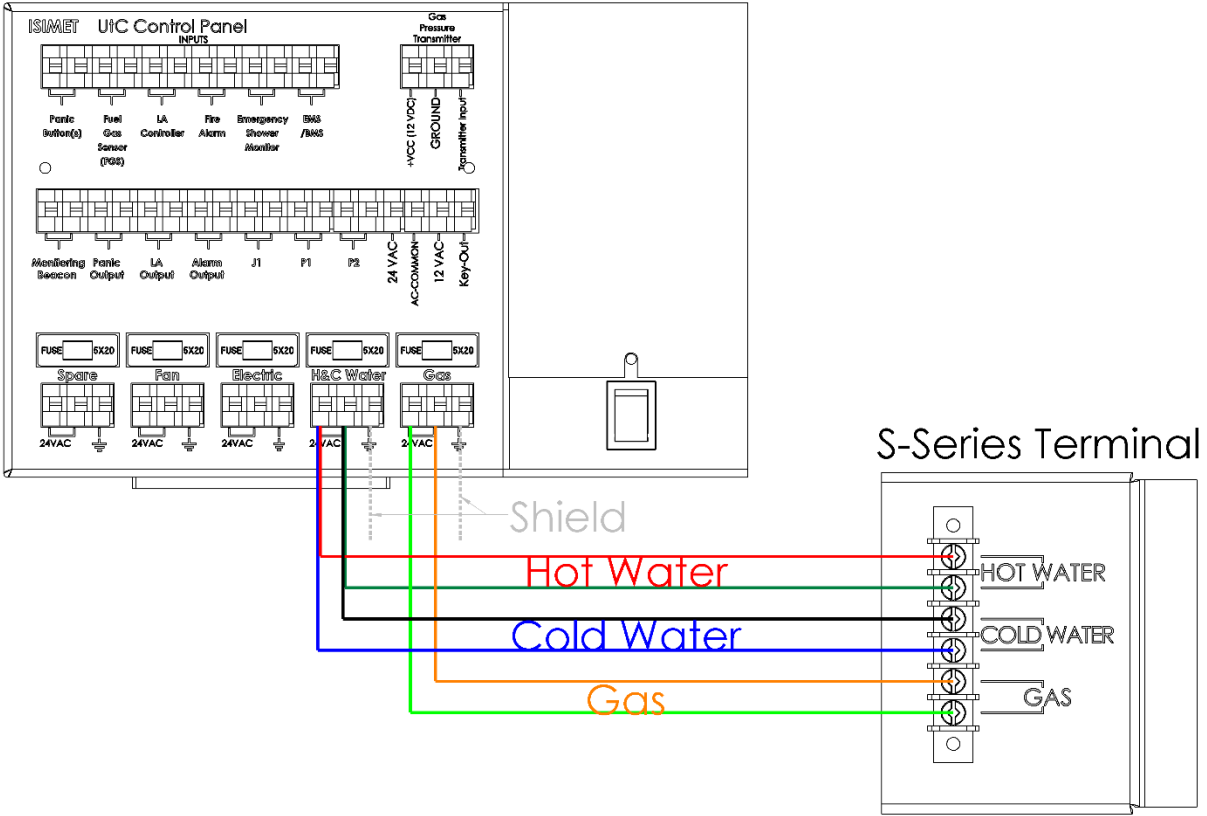

Use 2x 18/4 AWG shielded control wiring to connect these terminals. It is recommended to use wire labels to label each wire as they are being run.

UtC Control Panel	S-Series Terminal
<i>H&C Water (2-wires)</i>	<i>Hot Water</i>
<i>H&C Water (2-wires)</i>	<i>Cold Water</i>
<i>Gas (2-wires)</i>	<i>Gas Terminals</i>
<i>Extra Pair of Control Wire (2-wires)</i>	<i>Extra Pair of Control Wire</i>

E-Series and Exhaust Fan

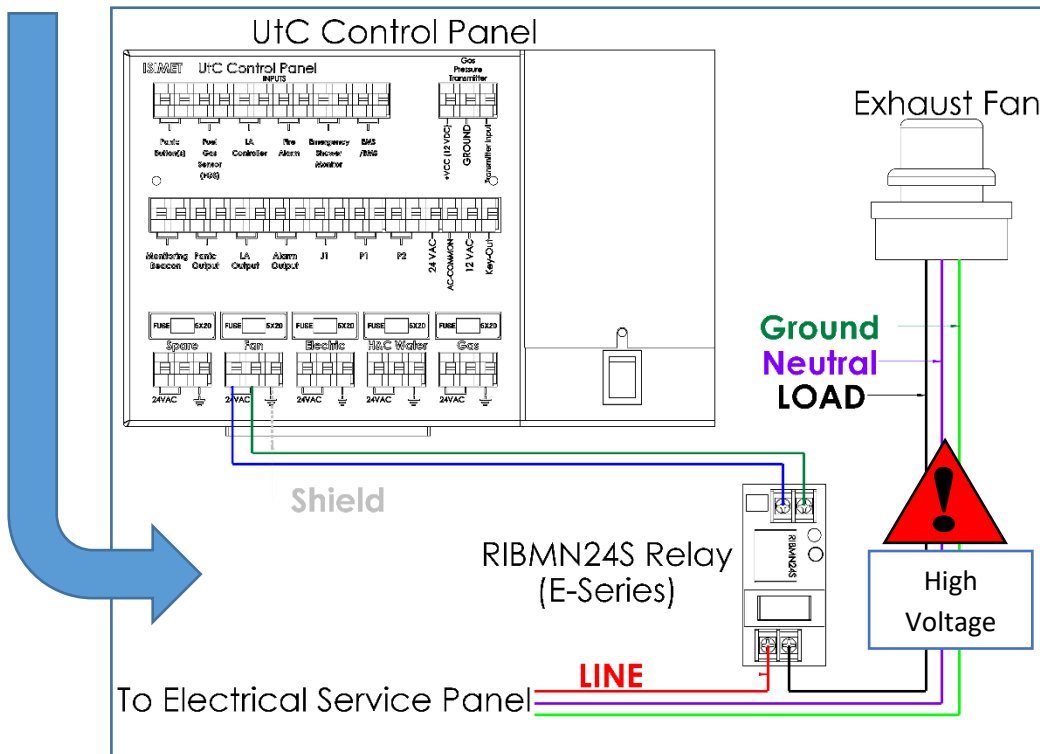
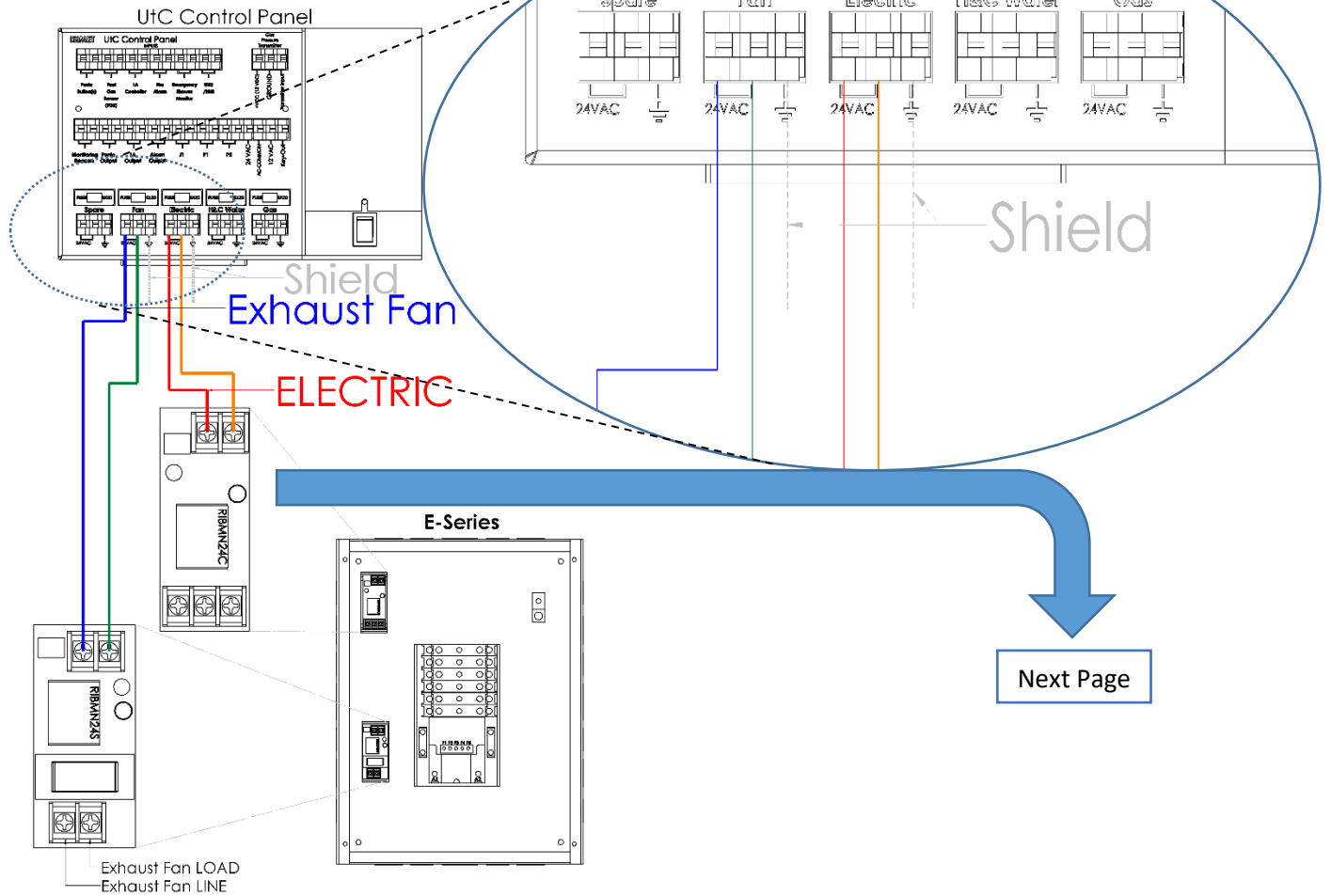

Connect up to (12)-120V Circuits to the E-Series (These circuits will be controlled by the Utility Controller).

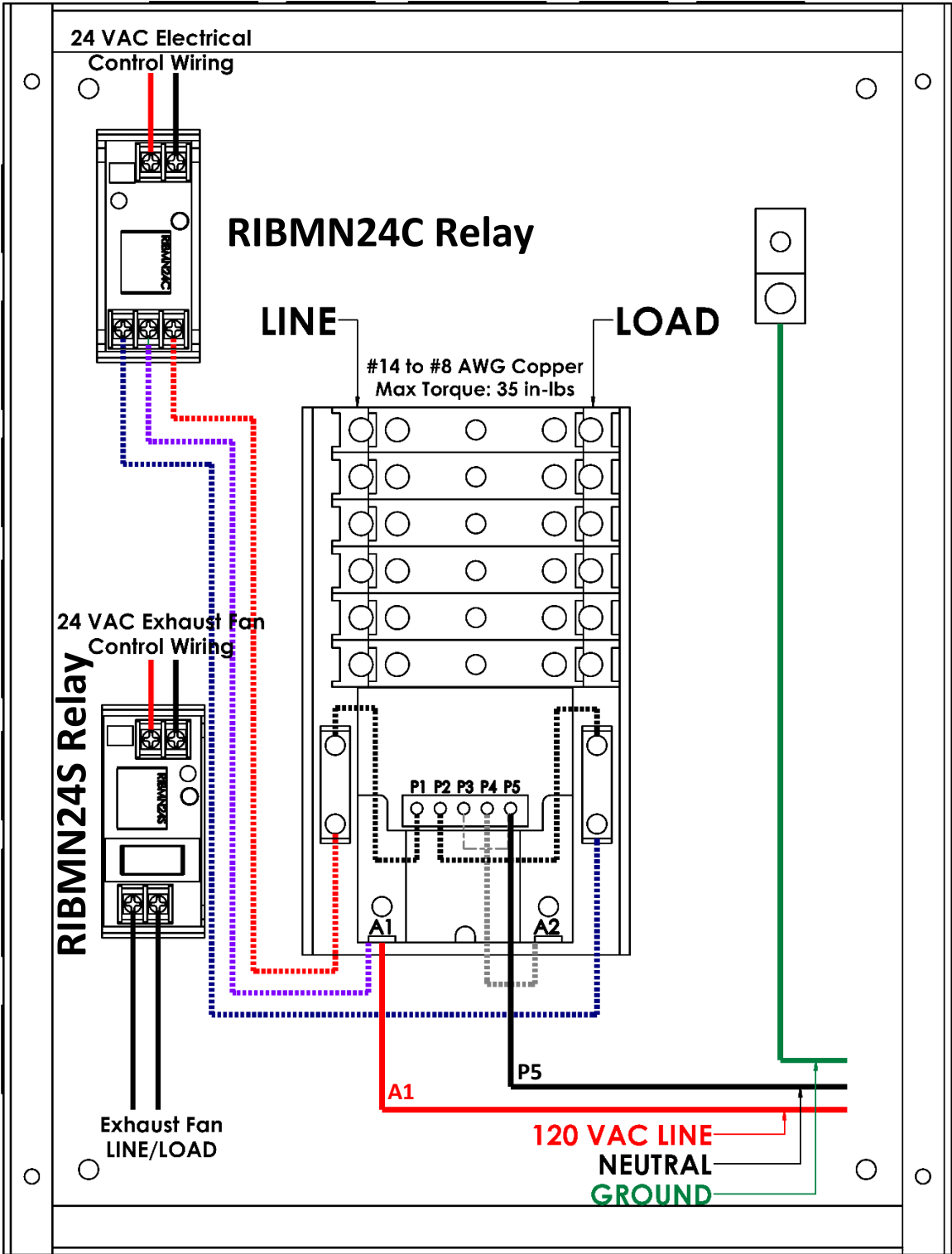

Note: Dashed lines indicate connections pre-made.

Note: RIBMN24S has 2 output terminals while RIBMN24C has 3.

RIBMN24C

UtC Control Panel	E-Series Relay
<i>Electric (Circuit #3)</i>	<i>RIBMN24C (Pin 1) Input</i>
<i>Electric (Circuit #3)</i>	<i>RIBMN24C (Pin 2) Input</i>
<hr/>	
E-Series RIBMN24C Relay Output	E-Series Electric Contactor
<i>Pin 1</i>	<i>Preconnected</i>
<i>Pin 2</i>	<i>Preconnected</i>
<i>Pin 3</i>	<i>Preconnected</i>

RIBMN24S

UtC Control Panel	E-Series Relay
<i>Spare Circuit (Circuit #5)</i>	<i>RIBMN24S (Pin 1) Input</i>
<i>Spare Circuit (Circuit #5)</i>	<i>RIBMN24S (Pin 2) Input</i>
<hr/>	
E-Series RIBMN24S Relay Output	E-Series Electric Contactor
<i>Pin 1</i>	<i>Exhaust Fan LINE</i>
<i>Pin 2</i>	<i>Exhaust Fan LOAD</i>

Contact Ratings:

15A General Use @ 125 VAC

10A General Use @ 277 VAC

½ HP @ 125 VAC

1 HP @ 250 VAC

¼ HP @ 277 VAC

Panic Button(s)

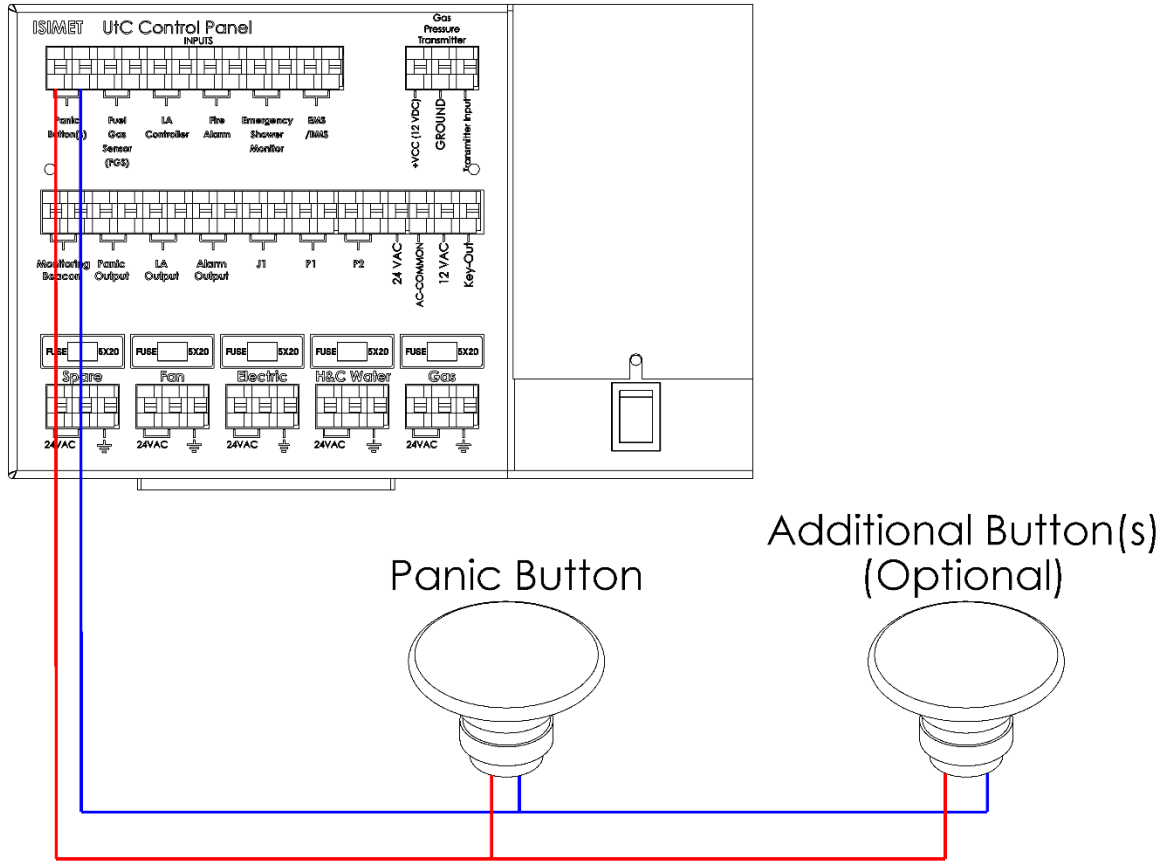

Multiple panic buttons can be attached to the UtC in parallel as long as they are Normally Opened (NO) emergency panic buttons.

UtC Control Panel		Panic Button	
<i>Panic Button(s)</i>		<i>PANIC BUTTON (Pin 1)</i>	
<i>Panic Button(s)</i>		<i>PANIC BUTTON (Pin 2)</i>	
Additional Panic Button(s)			
Panic Button 1		Panic Button 2	
<i>PANIC BUTTON 1 (Pin 1)</i>		<i>PANIC BUTTON 2 (Pin 1)</i>	
<i>PANIC BUTTON 1 (Pin 2)</i>		<i>PANIC BUTTON 2 (Pin 2)</i>	

Note: Additional Panic Buttons must be run in parallel. Test each button periodically to ensure proper functionality.

Fuel Gas Sensor

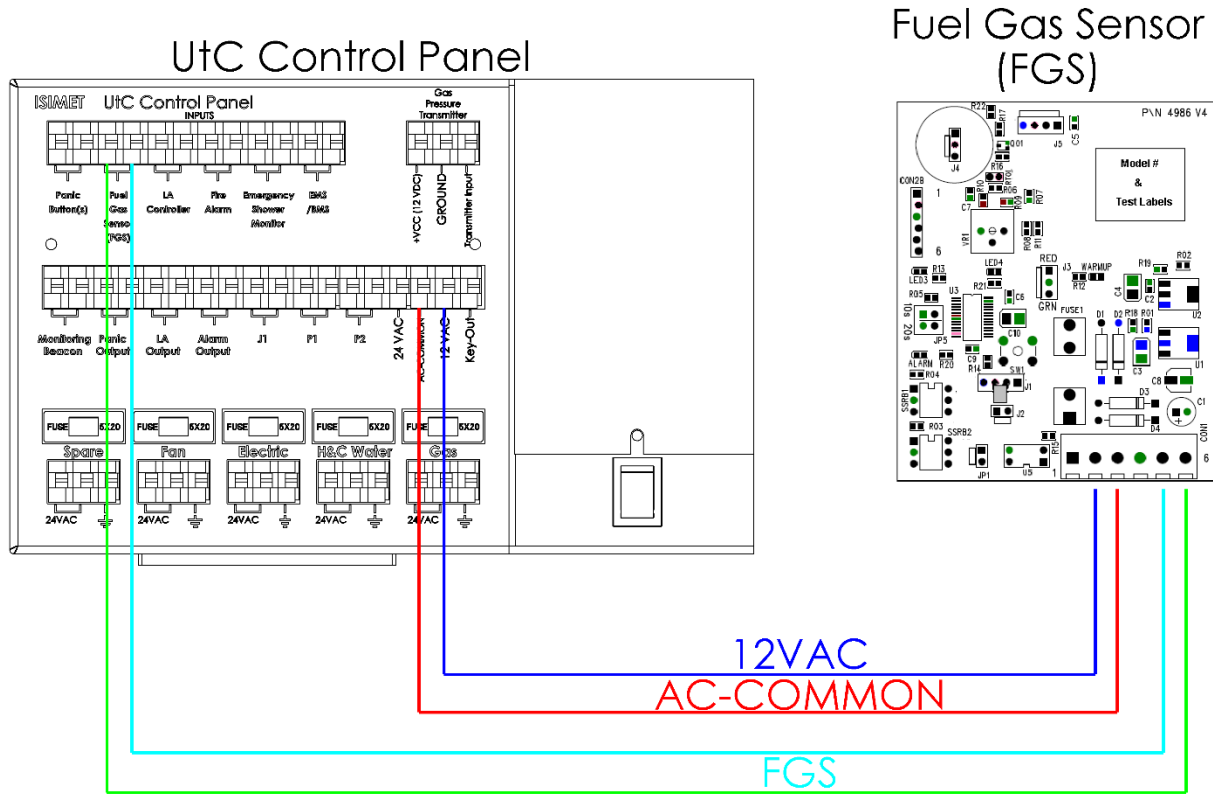

UtC Control Panel

Fuel Gas Sensor

<i>Fuel Gas Sensor (FGS)</i>	<i>CON1 (Pin 6)</i>
<i>Fuel Gas Sensor (FGS)</i>	<i>CON1 (Pin 5)</i>
<i>AC-COMMON</i>	<i>CON1 (Pin 4)</i>
<i>12VAC</i>	<i>CON1 (Pins 3 & 2)</i>

Emergency Shower Monitor

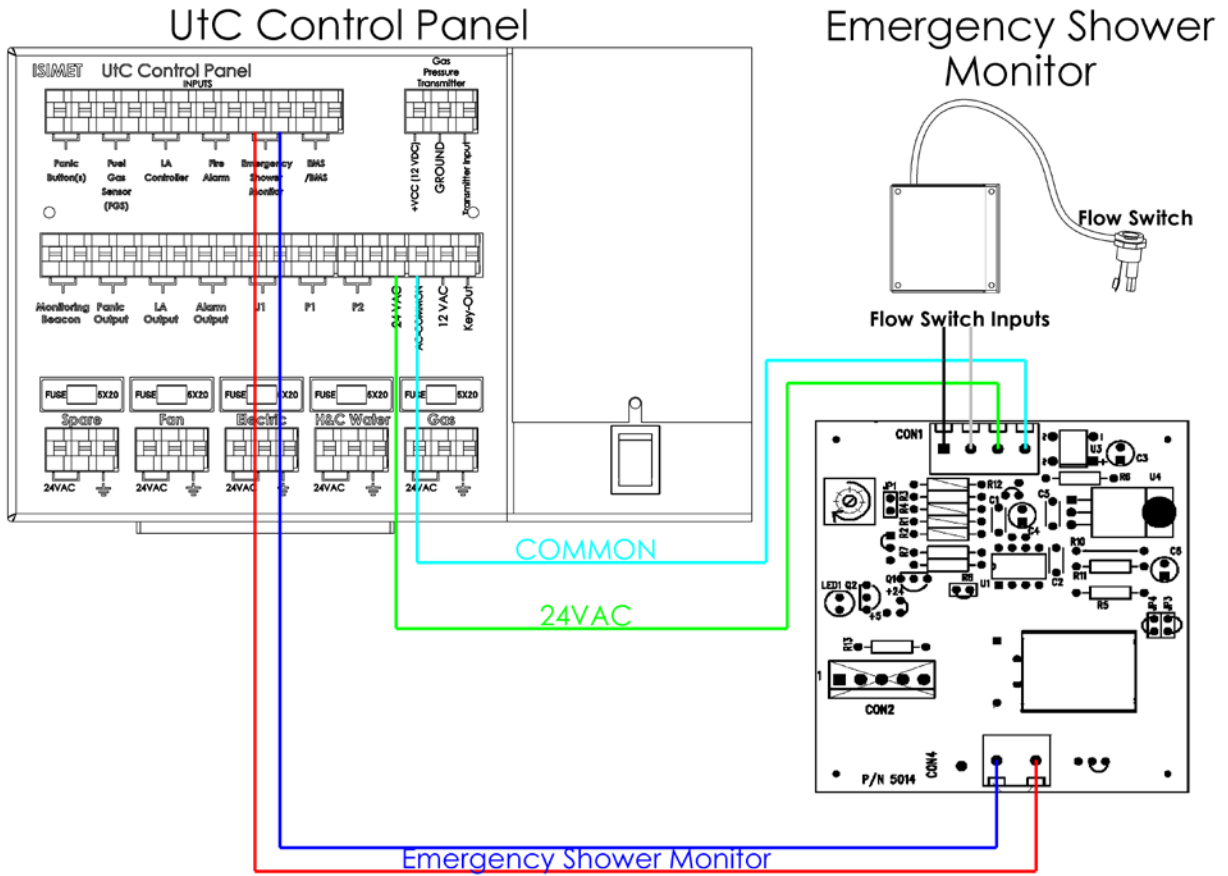

Note: After the flow switch is installed directly upstream of the emergency shower, the flow switch wiring should be inserted into the rubber grommet of the junction box and connected as shown.

UtC Control Panel

Emergency Shower Monitor

<i>Emergency Shower Monitor</i>	<i>CON4 (Pin 1)</i>
<i>Emergency Shower Monitor</i>	<i>CON4 (Pin 2)</i>
<i>Flow Switch Input (Black)</i>	<i>CON1 (Pin 1)</i>
<i>Flow Switch Input (White)</i>	<i>CON1 (Pin 2)</i>
<i>24VAC Out</i>	<i>CON1 (Pin 3)</i>
<i>COMMON</i>	<i>CON1 (Pin 4)</i>

Monitoring Beacon

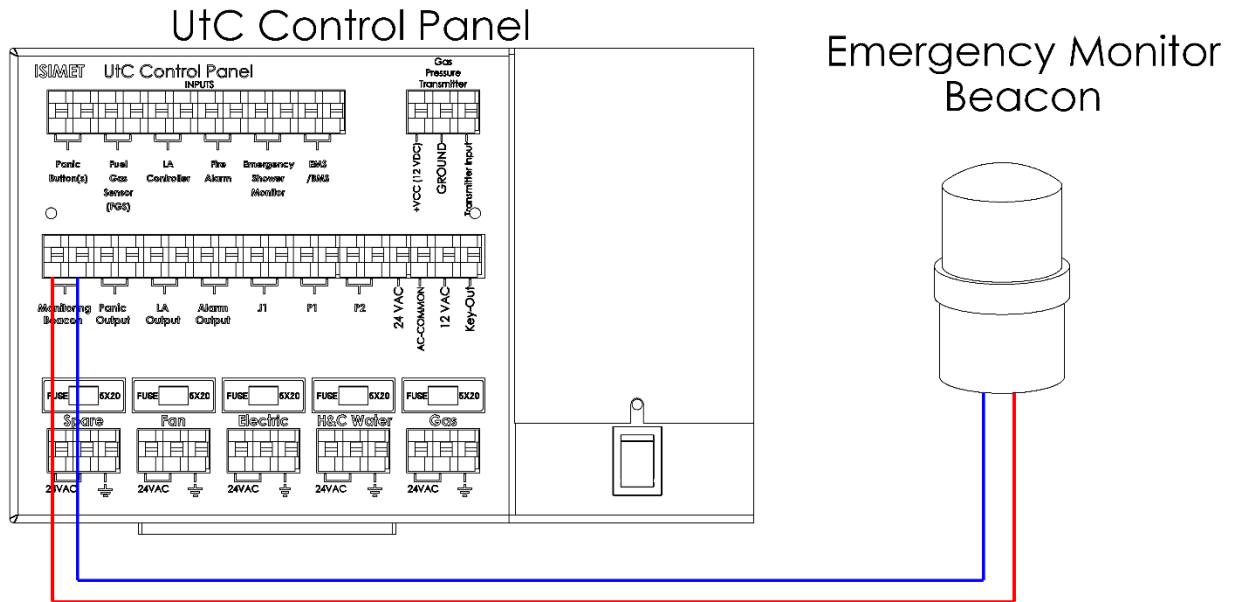

UtC Control Panel

Emergency Monitor Beacon

<i>Monitoring Beacon</i>	<i>Black</i>
<i>Monitoring Beacon</i>	<i>White</i>

Gas Pressure Transmitter (Optional)

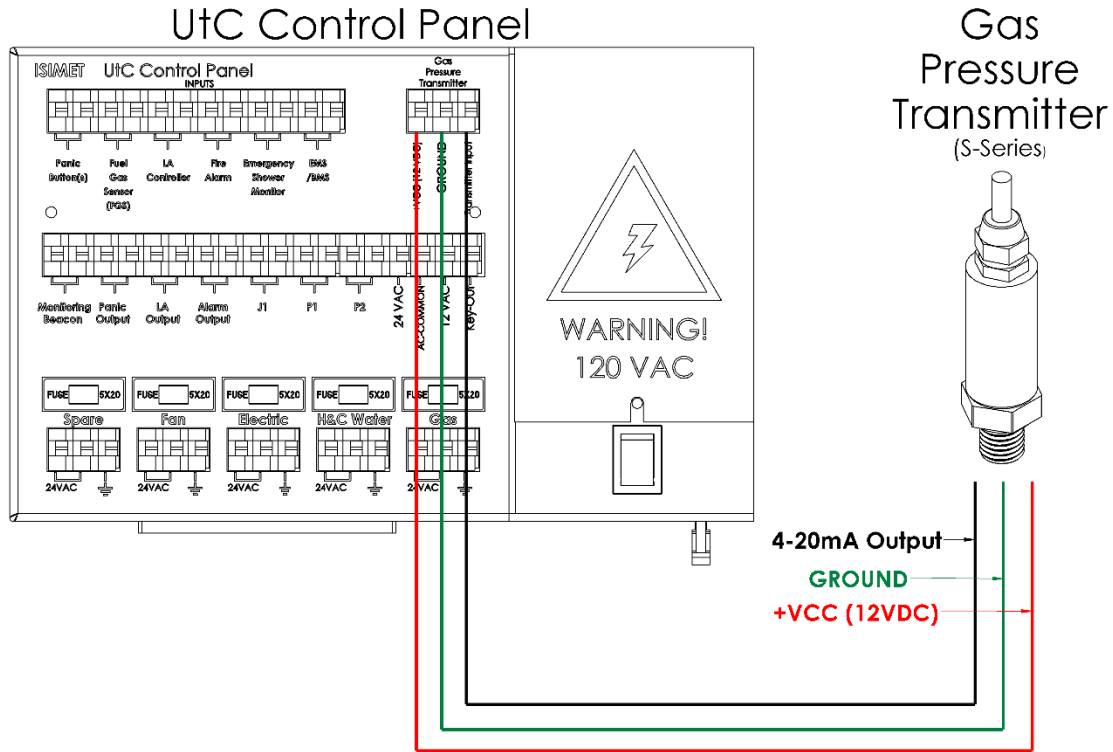

WARNING: Gas Pressure Transmitter cannot handle pressures exceeding 45 psi.

UtC Control Panel	Pressure Sensor
+VCC (12VDC)	+VCC (12VDC)
<i>Ground (GROUND)</i>	<i>Ground</i>
<i>Pressure Transmitter (Input) (PS Input)</i>	<i>4-20mA Output</i>

Building Fire Alarm (Optional)

Dry-Contact Input. The default configuration settings disable all utilities as long as an Alarm signal is present. The utilities can be reactivated once the Alarm signal is deactivated and re-keying the UtC.

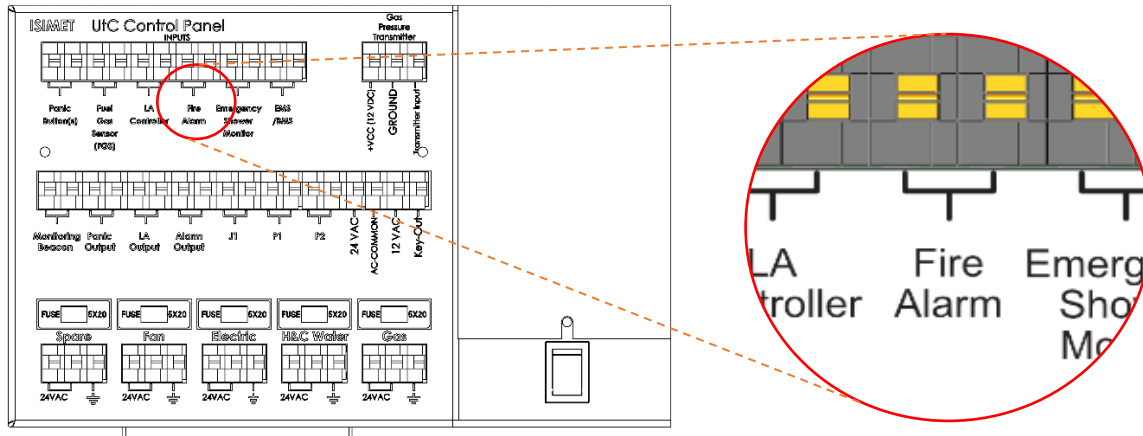

See Hardware Configuration Settings (Jumpers)

Building Energy Management System-EMS/BMS (Optional)

Dry-Contact Input. The same EMS system, found in many public facilities, that activates the heating and cooling system, will provide a higher degree of authority to activate the Utility Controller. The Utility Controller will only work when the EMS is active (or inactive with a programming change) and the controller has been “keyed” on.

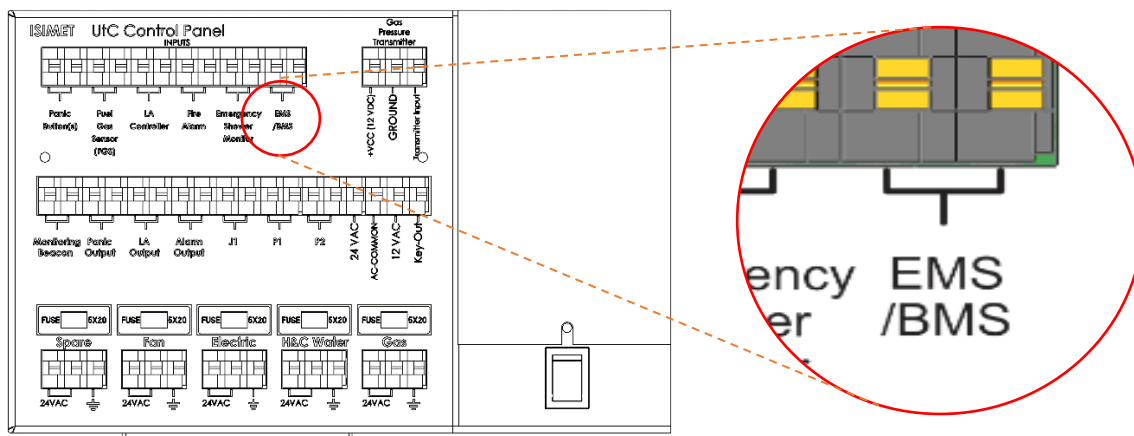

See Hardware Configuration Settings (Jumpers)

Hardware Configuration Settings (Jumpers)

The UtC must be configured properly if using a Building Fire Alarm or EMS/BMS. Otherwise, this section can be skipped.

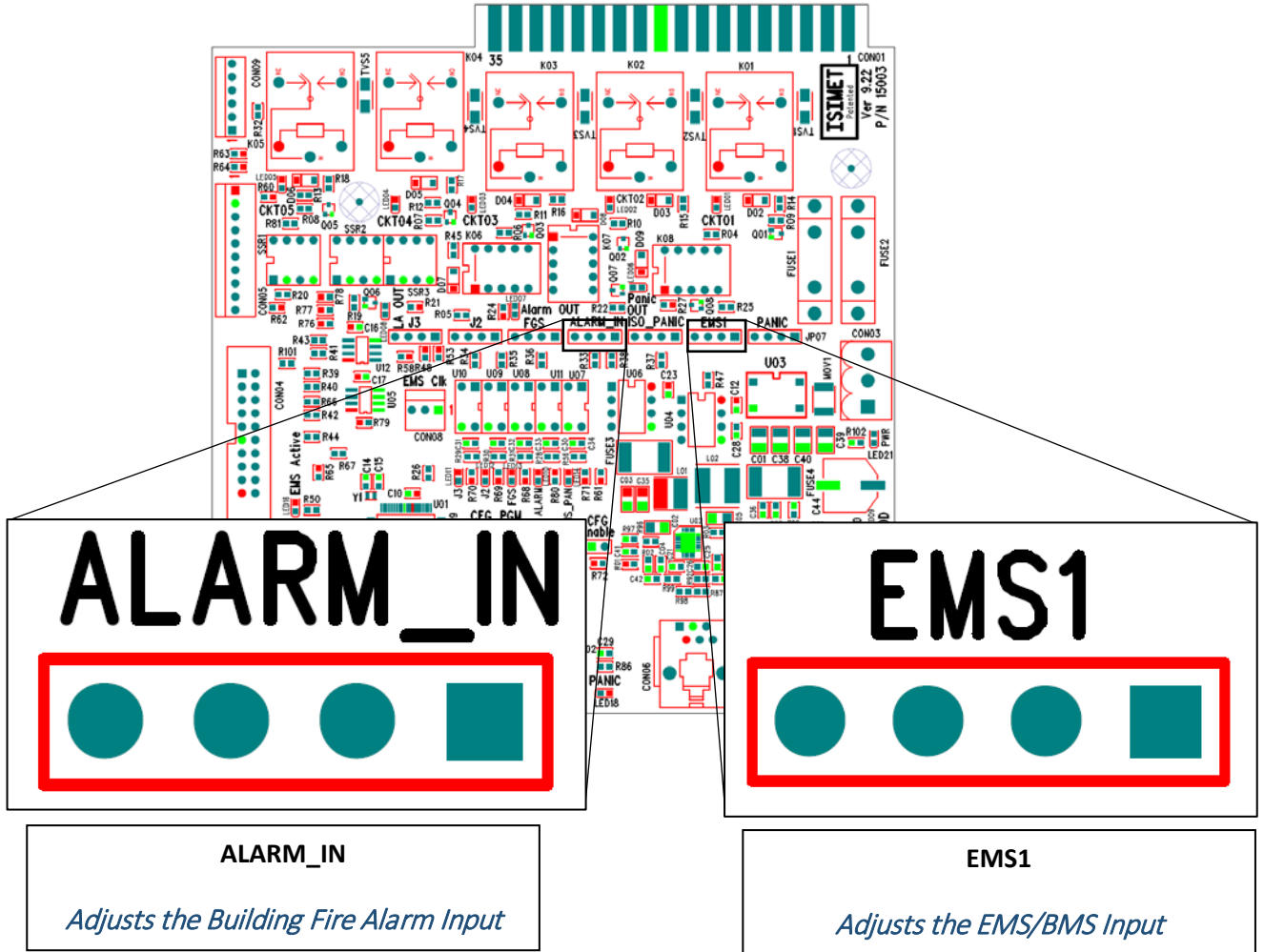

Installation Options and Method

- **24VAC or 24VDC Input Signal:**
 - **Single Jumper**

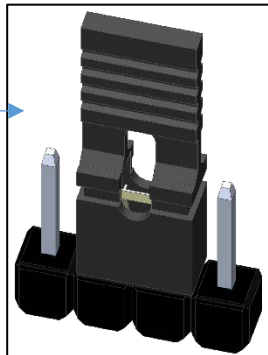

- **No Electrical Input Signal (Dry-Contact) Signal:**
 - **Default: 2 Jumpers**

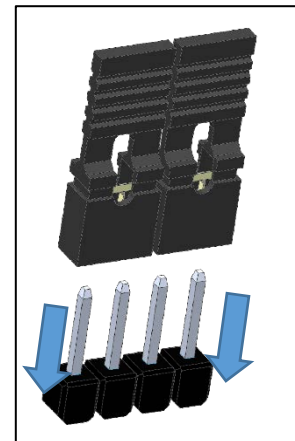

Connecting Power to the UtC

1. Turn off the breaker supplying 120VAC to the UtC
2. Turn off the power switch on the UtC Control Panel
3. Remove the 120V cover from the UtC Control Panel
4. Connect the following wires:
 - Green: Ground
 - White: Neutral
 - Black: 120VAC
5. Replace the UtC cover
6. **DO NOT TURN ON POWER UNTIL COMPLETING THE START-UP PROCEDURE**

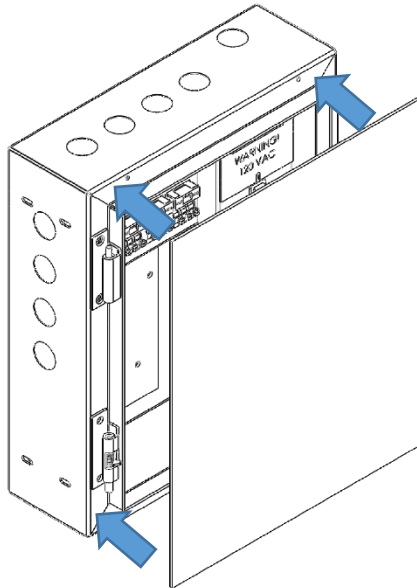

Reinstall the cardboard protective covering to protect the UtC while the walls are finished.

STOP:

Wait until the walls are finished before continuing

Installing the UtC and S-Series Trim Plate

1. Slide the trim plate over the enclosure.

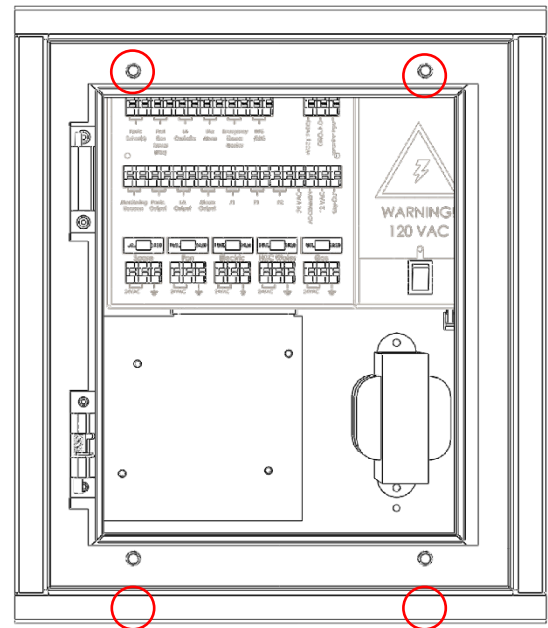
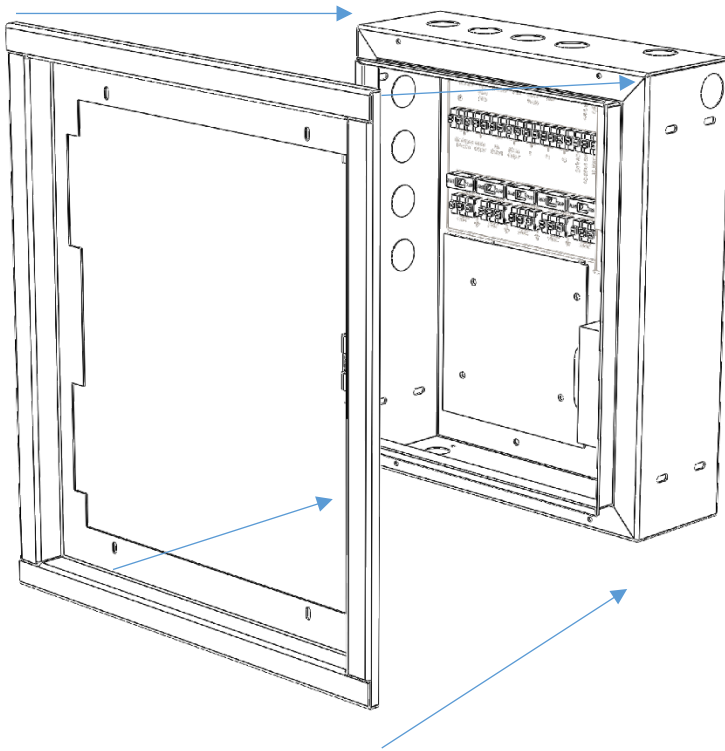

2. Align holes on enclosure with upper and lower holes in door trim.
3. Insert four (4) #6-32 screws through trim and tighten into the enclosure.

Installing Covers

1. Install the included Stainless-Steel Covers for the Fuel Gas Sensor, Panic Button(s), Emergency Shower Monitor, and Emergency Monitoring Beacon.
2. Install the E-Series Cover
3. Install the S-Series Door and ensure it is locked.

Installing UtC Door Panel

Step 1

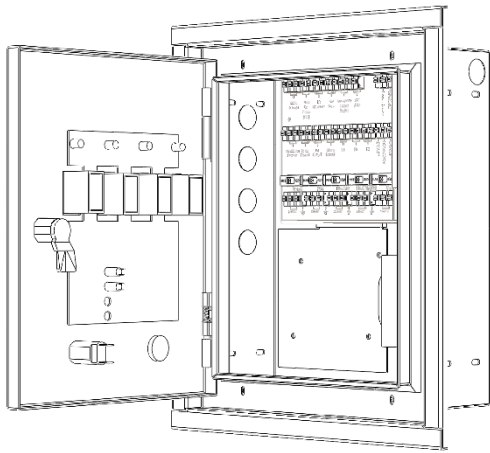

Position the door at 90° – 100° of enclosure.

Step 2

Slide the top hinge pin onto the fixed hinge post at the top of door

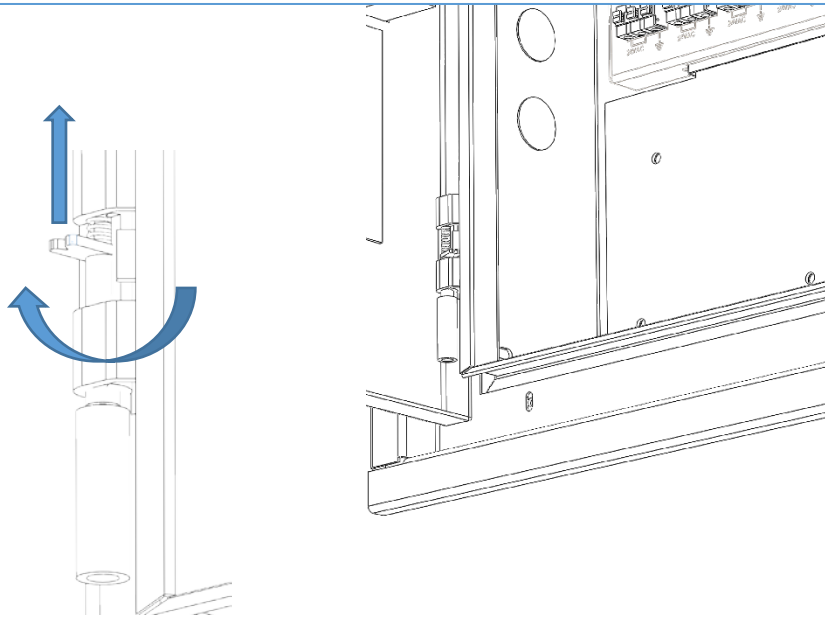
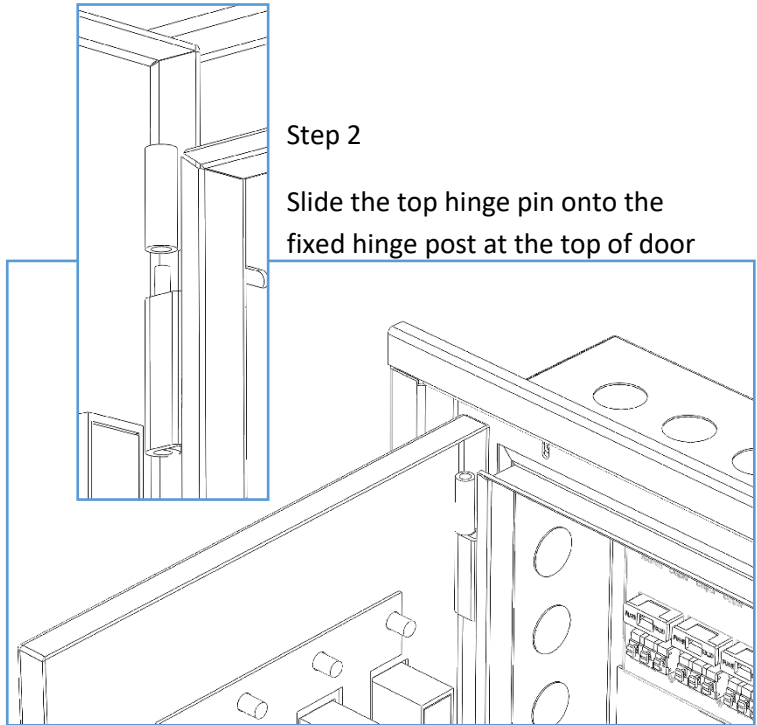

Step 3 Rotate the spring hinge and press up to insert the door.

Step 4

With the lower hinge lined up, turn the hinge pin lever to lock the hinge into position.

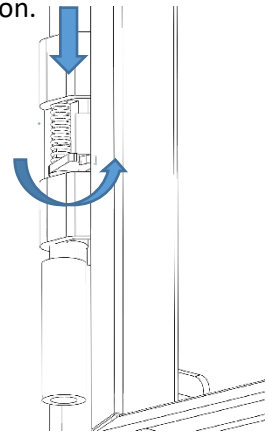

UtC Fuse Specifications

Used On		Label	Size	Description
3A - 5A Transformer		Fuse 1	5 x 20 mm	5A Slow-Blow
Center Tap (12VAC) Only		Fuse 2	5 x 20 mm	5A Slow-Blow
UtC Control Panel		ALL	5 x 20 mm	2A Fast-Acting

NOTE: Fuse 2 is only used with 12VAC. The Control Panel fuses are all 2A fast-acting fuses. These protect the primary side of the transformer as well as all of the circuit outputs. If one of these has blown, check for what caused the issue and fix before replacing these fuses.

Acronyms and Common Terms

UtC: ISIMET Utility Controller

Dry-Contact: Voltage free connection. Connect only to a switch that does not have an applied voltage.

NFPA: National Fire Protection Agency

ADA: Americans with Disabilities Act

ISIMET: Innovating Systems Integrating Mechanical and Electrical Technology

EMS/BMS: Building Energy Management System

PCB: Printed Circuit Board

FGS: Fuel Gas Sensor

EMT: Electrical Metallic Tubing

E-Series: ISIMET Electrical Panel

S-Series: ISIMET Gas and Water Solenoid Panel

Control Panel Terminal Definitions

: *Earth Ground*

Not to be confused with **GROUND**. This should ONLY be used to connect all wire shielding from the 18AWG/4 control wiring.

Gas (Circuit #1):

24VAC Output for the first circuit. Controlled by Switch 1 (typically Gas) on the UtC Door Panel. Circuit 1 should be connected to these terminals and the shield should be connected to Earth Ground.

H&C Water (Circuit #2):

24VAC Output for the second circuit. Controlled by Switch 2 (typically Water) on the UtC Door Panel. Circuit 2 should be connected to these terminals and the shield should be connected to Earth Ground.

Electric (Circuit #3):

24VAC Output for the third circuit. Controlled by Switch 3 (typically Electric) on the UtC Door Panel. Circuit 3 should be connected to these terminals and the shield should be connected to Earth Ground.

Exhaust Fan (Circuit #4):

24VAC Output for the fourth circuit. Controlled by Switch 4 (typically Exhaust Fan), if used on the UtC Door Panel. Circuit 4 should be connected to these terminals and the shield should be connected to Earth Ground.

Spare Circuit (Circuit #5):

24VAC Output for the fifth circuit. Controlled remotely. Circuit 5 should be connected to these terminals and the shield should be connected to Earth Ground.

Panic Button(s):

Connect to normally open (NO) panic buttons. Will cause the Utility Controller to enter Panic Mode and disable the utilities.

Fuel Gas Sensor (FGS):

Connect to ISIMET's Fuel Gas Sensor (FGS).

LA Controller:

Connect to ISIMET's LA (Limited Application) Companion/Controller.

Fire Alarm:

Connect to Building Fire Alarm. Will disable the Utility Controller. Configurable dry-contact or 24VAC input. Default is dry-contact.

Emergency Shower Monitor:

Connect to ISIMET's Emergency Shower Monitor. Can also be used as a secondary panic input.

EMS/BMS:

Energy Management System (EMS) or Building Energy Management System (BMS) input.

Gas Pressure Transmitter

+VCC (12VDC):

12VDC Output for the Gas Pressure Transmitter.

GROUND:

Not to be confused with . This should ONLY be used to connect the Gas Pressure Transmitter ground wire. This is an isolated ground and should NOT be connected in any way to Earth Ground.

Transmitter Input:

Gas Pressure Transmitter Input.

Miscellaneous

Monitoring Beacon Output:

Connect this output to ISIMET's 24VAC Monitoring Beacon.

Panic Output:

Dry-Contact Output when the Utility Controller is in Panic.

LA Output:

Dry-Contact Output for the LA Controller.

A1 Output:

24VAC Configurable output typically used for Alarm. Can be configured and connected to electrical utilities to remain ON until Alarm or Panic (Electric until Panic Off). Do NOT connect unless specifically told by ISIMET.

J1 Input:

LA Controller Input configurable between dry-contact and 24VAC. Do NOT connect unless specifically told by ISIMET.

P1 Output:

24VAC Panic Output. Do NOT connect unless specifically told by ISIMET.

A2/P2 Output:

24VAC Configurable Output from the UtC Field Configuration. Default use is for an Electric Contactor to be connected for circuits that remain ON at all times except by Panic or Alarm.

24VAC:

24VAC Output between this connection and AC-Common. Do NOT connect unless specifically told by ISIMET.

AC-COMMON:

Do NOT connect unless specifically told by ISIMET.

12VAC:

12VAC Output between this connection and AC-Common. Do NOT connect unless specifically told by ISIMET.

Key-Out:

24VAC Output between this connection and 24VAC when the service key is turned. Do NOT connect unless specifically told by ISIMET.